



Novatek-Electro TR-101 Documentation

<https://www.overvis.com/docs/pl/tr-101/>

2026-03-30

Table of Contents

1. Novatek-Electro TR-101
2. TR-101 Operating Manual
3. Appendix A: RS-485 Communication Interface
4. Appendix B: Device Adjustment

Novatek-Electro TR-101

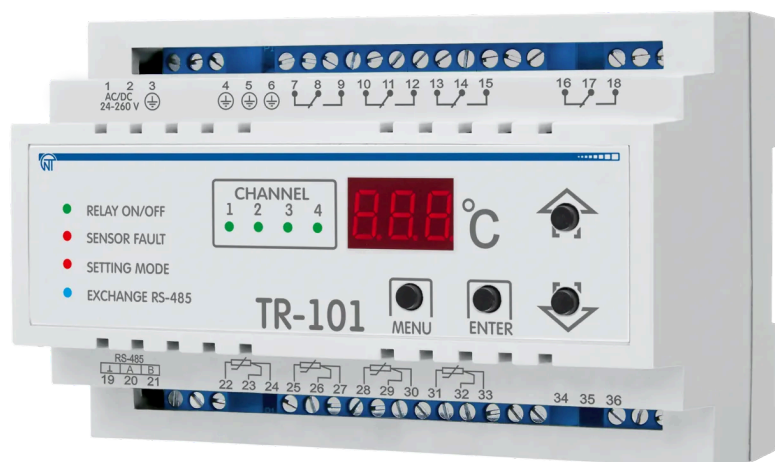

TR-101 to cyfrowy przekaźnik temperaturowy produkowany przez NOVATEK-ELECTRO LTD. Przeznaczony do pomiaru i regulacji temperatury z użyciem do czterech czujników.

 **Dostępna pełna dokumentacja**

Wyświetl całą dokumentację na jednej stronie – Idealna do drukowania lub czytania offline

Kluczowe cechy

- Pomiar temperatury na 4 kanałach ze standardowymi czujnikami RTD
- Regulacja temperatury PID (proporcjonalno-całkująco-różniczkująca)
- Regulacja temperatury dwupozycyjna (włącz-wyłącz)
- Obsługa różnych typów czujników: Pt50/100/500/1000, Cu50/100, Ni100/120/500/1000, PTC1000
- Interfejs RS-485 z protokołem Modbus RTU
- 4 wyjścia przekaźnikowe o zdolności przełączania 10 A

Dokumentacja

- **Instrukcja obsługi**

Dokumentacja techniczna

- **Dodatek A: Interfejs RS-485**
- **Dodatek B: Regulacja urządzenia**

Zasoby dodatkowe

- Strona produktu TR-101 – Pełne informacje o produkcie i specyfikacje
- Dokumentacja jednostronicowa – Kompletna dokumentacja na jednej stronie do drukowania
- Pełna instrukcja TR-101 (PDF) – Kompletna instrukcja obsługi

Wsparcie

- **Centrum wsparcia:** Odwiedź nasze Centrum wsparcia
- **Zgłoś problem:** Wyślij zgłoszenie

TR-101 Operating Manual

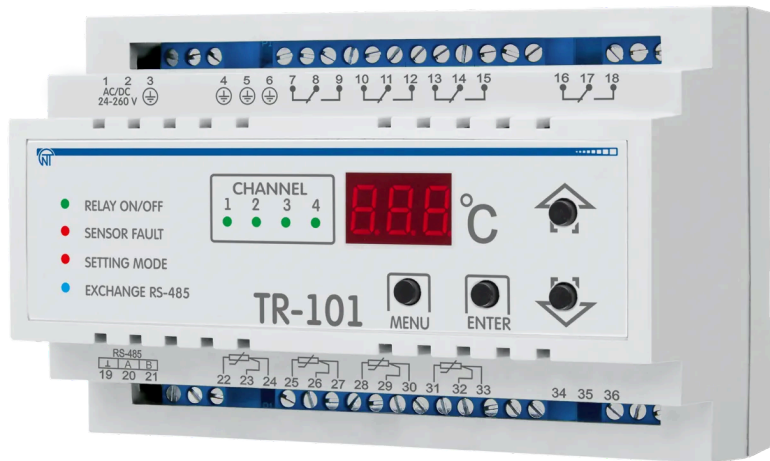

NOVATEK-ELECTRO LTD

Intelligent Industrial Electronics

DIGITAL TEMPERATURE RELAY TR-101

OPERATING MANUAL

Quality control system on the development and production complies with requirements ISO 9001:2015

Dear customer,

Company NOVATEK-ELECTRO LTD. thanks you for purchasing our devices.

You will be able to use properly the device after carefully studying the Operating Manual.

Keep the Operating Manual throughout the service life of the device.

UKRAINE, Odesa — www.novatek-electro.com

 **WARNING**

Review the Operating manual before using the unit.

Do not use abrasives or organic compounds for cleaning (spirit, gasoline, solvents, etc.).

NEVER ATTEMPT TO REMOVE AND REPAIR THE UNIT.

NEVER ATTEMPT TO OPERATE THE UNIT WITH THE MECHANICAL DAMAGE OF THE HOUSING.

NEVER ATTEMPT TO OPERATE THE UNIT UNDER CONDITIONS OF HIGH HUMIDITY. DO NOT LET WATER INTO THE UNIT.

This unit is safe for use in case of compliance with operating rules.

This manual is provided in order to introduce the operating personnel with structure, operating principle, design, mode of operation and maintenance of TR-101 digital temperature relay (further referred to as "device", "TR-101" or "TR-101 unit").

TR-101 complies with requirements:

- EN 60947-1
- EN 60947-6-2
- EN 55011
- EN 61000-4-2

No harmful substances in excess of the maximum permissible concentration is available.

1 Application

TR-101 is designed for measuring and controlling a device temperature by means of four sensors connected according to a two- or three-wire diagram, with subsequent temperature display. The device can find various applications in industrial sector, in municipal utilities service, and agriculture.

The device allows for performing the following functions:

- taking temperature measurement on 4 channels with use of standard sensors;
- controlling temperature according to proportional-integral-differential (PID) principle;
- temperature on-off regulation;
- displaying currently measured temperature value on the integral LED digital display;
- transferring the measured values for the sensors monitored via Modbus RTU standard protocol;
- defining a break or a short circuit on the connected sensors lines;
- measured temperature digital filtering and correction;
- programming by the front panel keys and via PC; settings backup when de-energized;
- settings protection from unauthorized change.

TR-101 has a flexible power supply and can use any voltage from 24 to 260 V, regardless of polarity.

Supported Temperature Sensors

TR-101 can use the following types of temperature sensors:

Table 1 – Supported Temperature Sensors

Sensor type	Rated resistance at 0 °C, R0, Ohm	USC notation (national)	USC notation (international) W100=1.3850	USC notation (international) W100=1.3910	Temperature range
Platinum	50	50П	Pt50	Pt'50	-50...+200 °C
Platinum	100	100П	Pt100	Pt'100	-50...+200 °C
Platinum	500	500П	Pt500	Pt'500	-50...+200 °C
Platinum	1000	1000П	Pt1000	Pt'1000	-50...+200 °C
Copper	50	50M	Cu50	Cu'50	-50...+200 °C
Copper	100	100M	Cu100	Cu'100	-50...+200 °C
Nickel	100	100H	—	Ni100	-50...+180 °C
Nickel	120	120H	—	Ni120	-50...+180 °C
Nickel	500	500H	—	Ni500	-50...+180 °C
Nickel	1000	1000H	—	Ni1000	-50...+180 °C
Other	990 at 25°C / 807 at 0°C	—	PTC1000	EKS111	-50...+100 °C

Note

W100 – ratio of sensor resistance at 100°C to its resistance at 0°C ($W100 = R100 / R0$)

- Platinum sensors: $W100 = 1.3850$ or $W100 = 1.3910$
- Copper sensors: $W100 = 1.4260$ or $W100 = 1.4280$
- Nickel sensors: $W100 = 1.6170$
- PTC1000/EKS111: $W100 = 2.0805$

2 Technical Specifications and Operating Conditions

2.1 Basic Technical Parameters

Table 2 – Basic Technical Parameters

Parameter	Value
Supply voltage	24 – 260 V AC/DC

Parameter	Value
Recommended fuse	1 A
Type of temperature measurement sensors	Pt50, Pt100, Pt500, Pt1000, Cu50, Cu100, Ni100, Ni120, Ni500, Ni1000, PTC1000
Quantity of sensors connectable	1 – 4
Sensors wiring schematic	2 / 3 wires
Sensor wire length (2-wire)	up to 5 m
Sensor wire length (3-wire)	up to 100 m
Quantity of output relays	4
Data memory	≥ 10 years
Temperature measurement error	± 2 °C
Measured temperature range	-50 to +200 °C
Output relay testing	available
RS-485 MODBUS RTU	available
PID regulation with key element (relay)	available
Two-position regulator	available
Channel measurement time	≤ 0.6 sec
Protection degree: enclosure	IP30
Protection degree: terminal block	IP20
Power consumption (under load)	≤ 4.0 VA
Weight	≤ 0.370 kg
Dimensions (H × W × D)	90 × 139 × 63 mm
Output contacts electrical life (10 A, 250 V AC)	≥ 100,000 cycles
Output contacts electrical life (10 A, 24 V DC)	≥ 100,000 cycles
Mounting	Standard 35 mm DIN-rail
Mounting position	Any

Output Contacts Specification

Cos φ	Max. current at 250 V AC	Maximum power	Max. voltage AC	Max. current at 30 V DC
1.0	10 A	4000 VA	440 V	3 A

2.2 Operating Conditions

The device is designed for operating in the following environment:

- Ambient temperature: -35 to +55 °C
- Storage temperature: -45 to +60 °C
- Atmospheric pressure: 84 to 106.7 kPa
- Relative air humidity (at temperature 35 °C): 30...80%

3 Equipment Design and Operation

3.1 TR-101 Device Equipment

Display Symbols

Trace of symbols at numeric display to letters of Roman alphabet is shown in Figure 3.



Figure 3 – Trace of symbols at numeric display to letters of Roman alphabet

3.1.1 Design

The device is manufactured in plastic casing (9 S-type modules) to be mounted onto standard DIN rail. The casing outline with overall and mounting dimensions is presented in Figure 3.1.

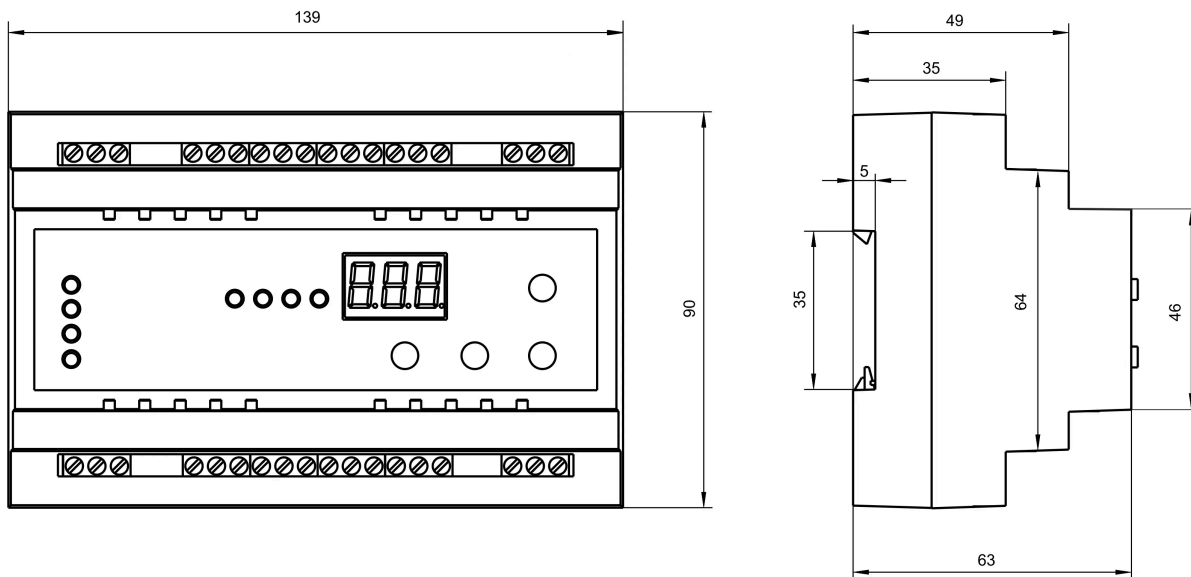
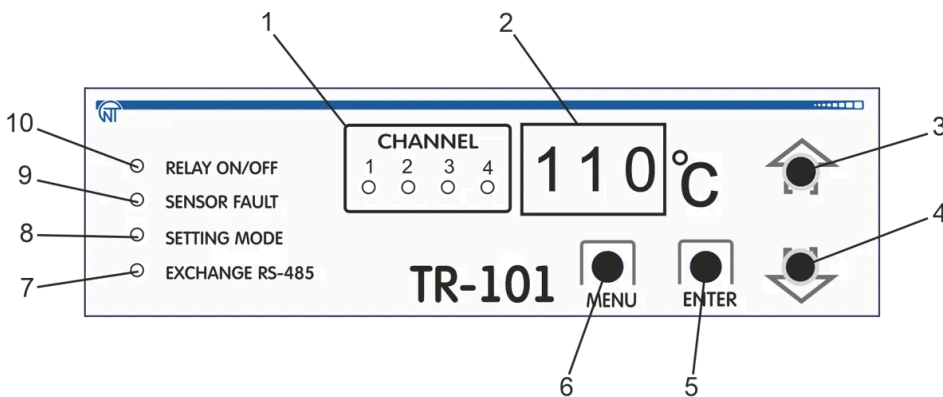

Figure 3.1 – TR-101 dimensions

3.1.2 Display and Control

Figure 3.2 presents the TR-101 front panel Exterior.



Front Panel Elements:

1. Currently displayed channel number indicator
2. Seven-digit numerical display
3. Up key (▲)
4. Down key (▼)
5. Enter key (ENTER), used in the device programming mode
6. View mode and device programming mode enter key (MENU)
7. RS-485 connection and communication activity indicator
8. Parameter programming mode indicator
9. Sensors failure indicator
10. Relay close (open) indicator

Figure 3.2 – TR-101 Front Panel

In the menu mode, indicators (1, 7) display the corresponding parameter (on/off): rSA, ch1, ch2, ch3, ch4 (see Table 7.1).

Device control:

- Use ▲▼ keys to toggle channels
- Use MENU key to enter the parameter view mode
- To enter the parameter edit mode – press MENU key and hold it within 7 seconds, the “setting” indicator (Fig. 3.2, item 8) shall light
- To save modified value – use ENTER key
- If no key has been pressed within 20 sec, TR-101 will display Ext sign (within 1 sec), and will switch to the initial state

3.2 Operating Principle and Input Signal Processing

3.2.1 Operating Principle

In course of its operation, TR-101 performs input sensors scanning, then, based on the data obtained, calculates the current temperature value and outputs it on the digital display and sends control signals to the corresponding channel relay.

3.2.2 Input Signal Processing

The signal that is received from sensor is transformed into a temperature digital value.

In order to eliminate the initial input signal processing error, as well as errors that are produced by the connection wiring, the device measured value can be adjusted. TR-101 provides for two adjustment types, which allow performing a gain shift or sloping by a specified degree for each channel independently.

3.2.3 Measurements Adjustment

3.2.3.1 Characteristic Shift

To provide for the error compensation $\Delta R = (R_0 - R_0.TC)$ produced by the input wiring resistance R_0 , each measured temperature value (T_{meas}) is added with a user specified value δ . Figure 3.3 shows an example of a characteristics shift for Pt100 sensor.

Programmable parameters: Sh1, Sh2, Sh3, Sh4

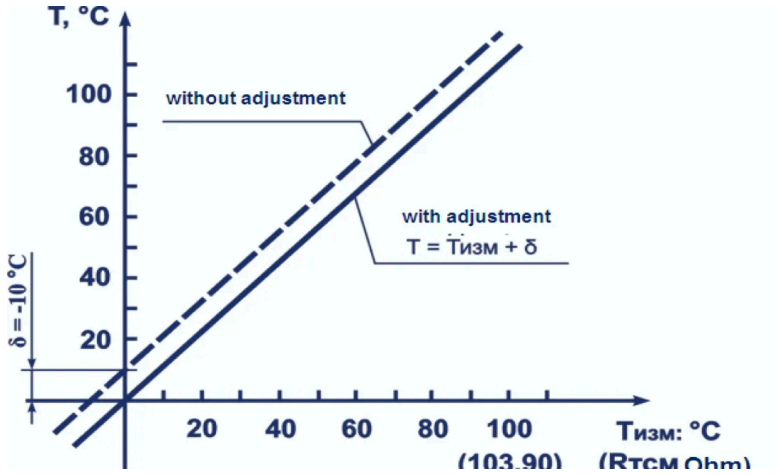

Figure 3.3 – Characteristic shift example for Pt100 sensor

3.2.3.2 Characteristic Slope

To provide for sensor error compensation upon W100 value deviation from the rated value, each Tmeas parameter measured value is multiplied by the user set adjustment parameter α .

The ratio boundaries are set within 0.50 to 2.00 limits. Figure 3.4 shows an example of the characteristic slant variation for Pt100 sensor.

Programmable parameters: KU1, KU2, KU3, KU4

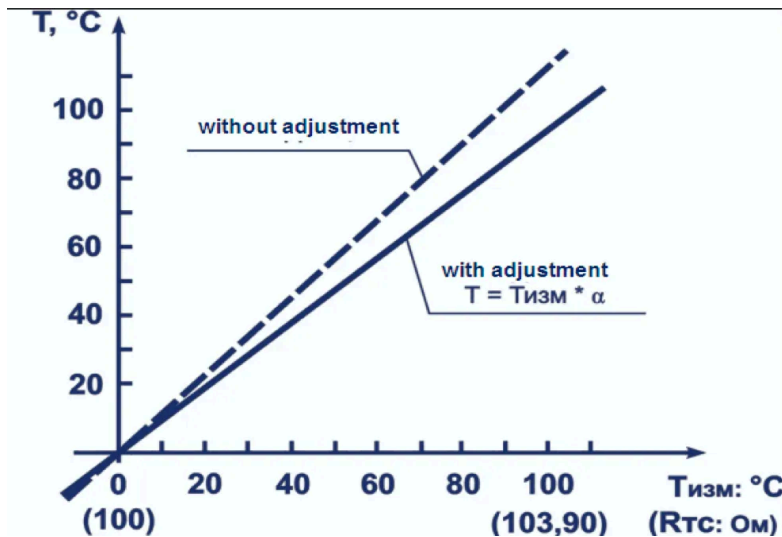

Figure 3.4 – Characteristic slope example for Pt100 sensor

3.2.4 Digital Filter

To provide for the input signal properties improvement the device employs digital filters that allow reducing the random interference effect on the temperature measurement.

Programmable parameters:

- Digital filter band: Fb1, Fb2, Fb3, Fb4
- Digital filter time constant: Ft1, Ft2, Ft3, Ft4

The filters are set for each input independently.

3.2.4.1 Digital Filter Band

The digital filter band allows protecting the measurement route from single interference and is set in °C. If the measured value **Tmeas** is different from the previous **Tmeas-1** by the value larger than the Fb parameter value, the device assigns to it a value equal to (Tmeas + Fb). Thus the characteristic is smoothed out.

Smaller band width of the filter leads to slowing down the device reaction to temperature change. That is why in case of low interference level or during operation with discontinuous temperatures it is recommended to increase the parameter value or switch off the filter band action by setting the Fb1 (Fb2, Fb3, Fb4) parameter value to 0.

When working under strong interference, in order to eliminate its impact onto the device operation, it is necessary to reduce the parameter value.

3.2.4.2 Digital Filter Time Constant

The digital filter eliminates the noise signal components by smoothing it exponentially. The main characteristic of the exponential filter is **τf** – the digital filter time constant, Ft1 (Ft2, Ft3, Ft4) interval, within which the temperature reaches the 63.2% from measured value **Tmeas**.

Reducing **τf** will lead to a faster device reaction onto discontinuous temperature variations, but also will reduce its protection against interference. Increasing **τf** value increases the device response rate, while noise is significantly suppressed.

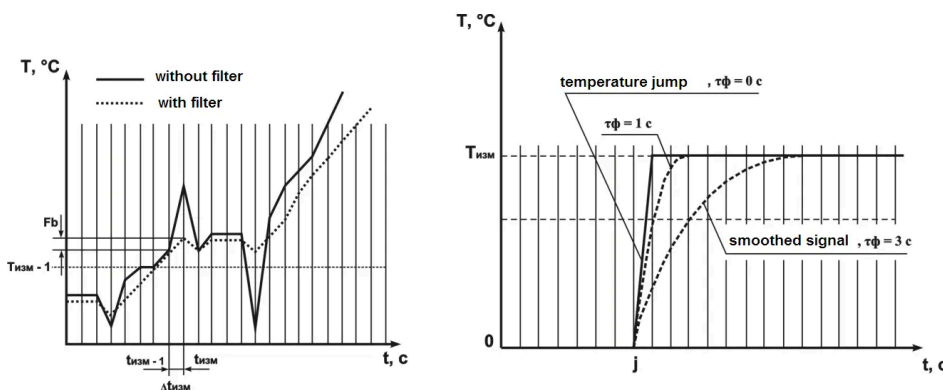

Figure 3.5 – Filter band characteristic **Figure 3.6** – Filter time constant characteristic

3.2.5 Two-Position Regulator (Two-Position Control)

In the two-position control mode the device works according to one of the two logic types:

Logic N°1 (Heater) – used to control a heater operation (tubular electric heaters, for instance), or to produce warning that the **current temperature value (Tcurr)** is less than the **setting value (Tset)**.

- The output relay initially closes at values of **Tcurr < Tset – HS**
- Then opens at **Tcurr > Tset + HS**

- And closes again at $T_{curr} < T_{set} - HS$

This effects the two-position control by **Tset** setting with the **HS** hysteresis.

Logic N°2 (Cooler) – used to control a cooler operation (a fan, for instance), or a warning of exceeding **Tset** setting value.

- The output relay initially is ON at values of $T_{curr} > T_{set} + HS$
- Then is OFF at $T_{curr} < T_{set}$
- And ON again at $T_{curr} > T_{set} + HS$

Caution

If using as compressor cooler, it is recommended to define **HS** in such a manner to provide the normal (minimum) compressor off time to avoid the device damage.

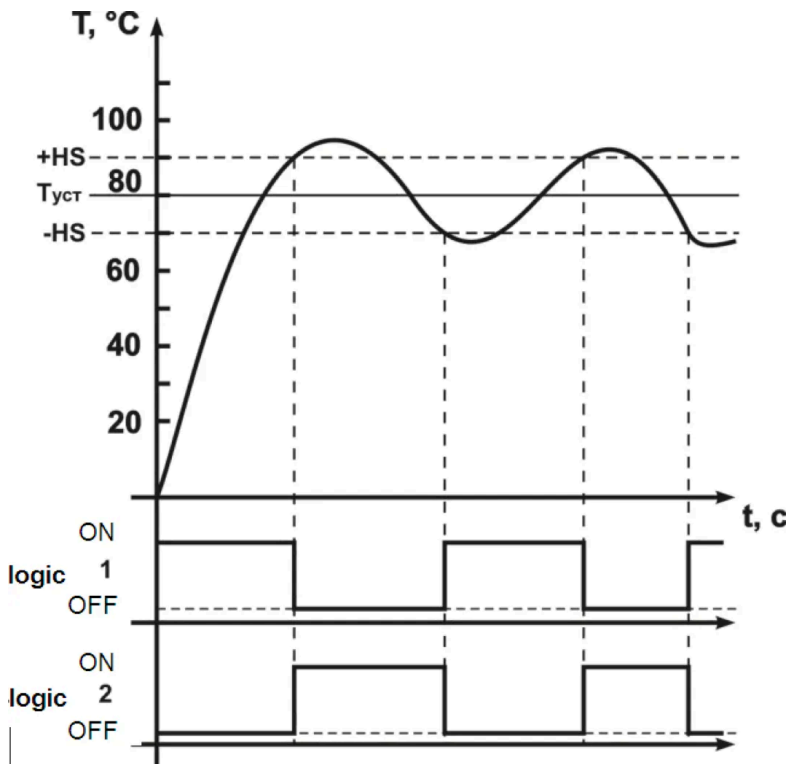

Figure 3.7 – Diagram of output relay function based on the logic type

Programmable parameters:

- **Tset** – temperature setting: SP1 (SP2, SP3, SP4)
- **HS** – hysteresis: HS1 (HS2, HS3, HS4)
- Relay function logic: rt1 (rt2, rt3, rt4)

3.2.6 PID-Controller (Proportional-Plus-Integral-Plus-Derivative Control)

3.2.6.1 PID Control General Principles

On the control relay the "controlling" signal Y_i is generated; its action is directed at reducing the E_i deviation.

$$Y_i = \frac{1}{X_p} \left(E_i + \frac{1}{\tau_i} \sum_{i=0}^n E_i * \Delta t_{meas} + \tau_d * \frac{\Delta E_i}{\Delta t_{meas}} \right) * 100\%$$

Where:

- **Xp** – proportionality band (programmable parameter P)
- **Ei** – is the difference between the set **Tset** and current **Tcurr** temperature value, or unbalance
- **td** – response speed derivation (programmable parameter "PID-controller derivative constant" - d)
- **ΔEi** – difference between two adjacent measurements E_i and E_{i-1}
- **Δtmeas** – difference between two adjacent measurements **Tcurr** and **Tcurr-1**
- **ti** – integration response time (programmable parameter "PID controller integral constant" i)
- Σ – derivation cumulative sum

To provide for the efficient PID controller operation it is important that proper values of **Xp**, **td** and **ti** ratios for the given controlled object be set.

Programmable parameters:

- **[Xp]** – P1 (P2, P3, P4)
- **[td]** – d1 (d2, d3, d4)
- **[ti]** – i1 (i2, i3, i4)

 **Note**

Sometimes PID regulation is overmuch or inadmissible. In such cases fixing coefficient **ti** = 0 or **td** = 0 is possible to get PD and PI regulator.

3.2.6.2 Proportional Regulator

Proportional regulator is the main where the task of temperature is directly proportional to error. Using only proportional regulator leads to error. The low values of proportional regulator lead to lack of stability and vibration in system but too high lead to low operation.

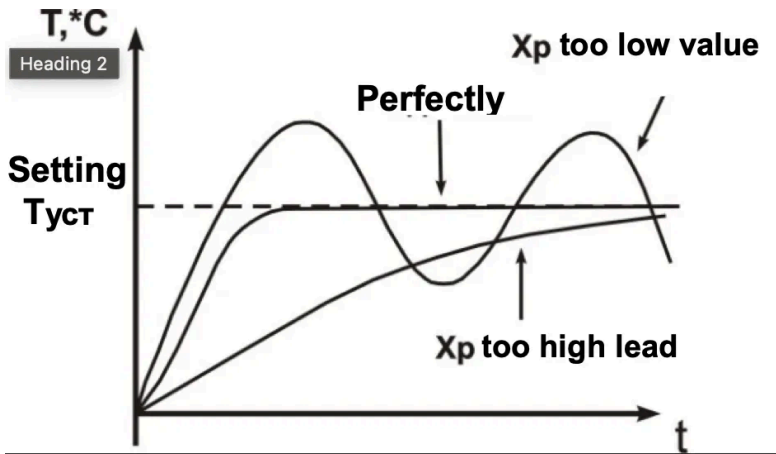

Figure 3.8 – Working diagram of proportional regulator

3.2.6.3 Integral Regulator

It's used for compensation of errors. The temperature will grow to the moment compensation of errors (or diminish by negative error). The minor constituents of integral element influence the regulator job much.

If the value fixed very high it means the system doesn't recognize it and will work with overshoot.

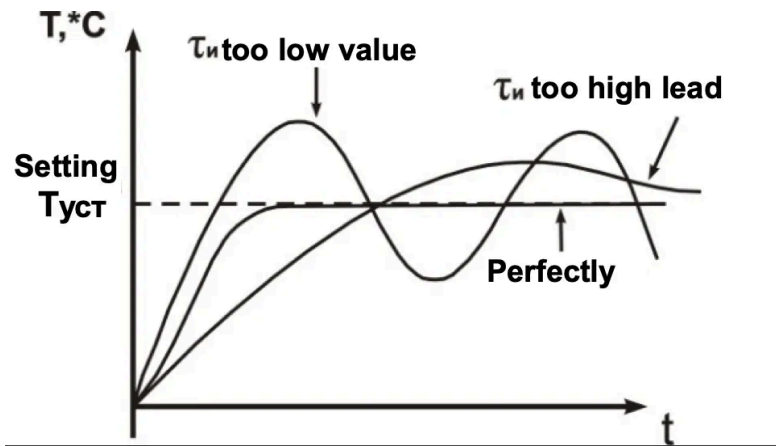

Figure 3.9 – Working diagram of integral regulator

3.2.6.4 Differential Regulator

It's used for increasing system performance rating the error change.

The regulator speeding leads to increasing overshoot and as a result is lack of stability the system.

Most cases derivative term is fixed neutral or low value to avoid this lack of stability.

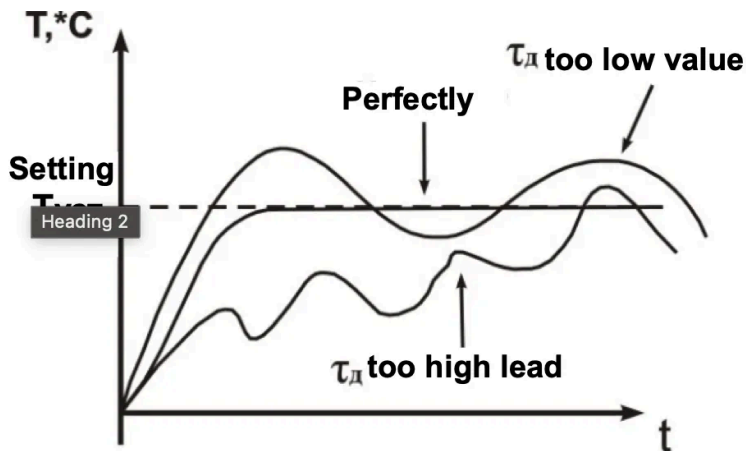

Figure 3.10 – Working diagram of differential regulator

3.2.6.5 Methods of PID Controlling

During the controlling, one of the control methods is selected: "Heater" or "Cooler".

- **Heater** – the output signal value decreases while the controlled temperature grows
- **Cooler** – the output signal value increases while the controlled temperature grows

Programmable parameters: rt1 (rt2, rt3, rt4)

Caution

Not recommended using PID control in cooler range of compressor in relation of lack control the minimal off time compressor can lead to damage device.

3.2.6.6 Action in PID-Regulator Mode with Output Key Element (Pulse-Length Modulation)

Command current from PID regulator (Y_i) is transforming to multiple pulses according to the following formula:

$$D = T_{\text{cycle}} \times Y_i / 100$$

Where:

- **D** – impulse duration (seconds): L1, L2, L3, L4
- **T_{cycle}** – pulse repetition period (seconds): t1, t2, t3, t4
- **Y_i** – command current of PID regulator (%)

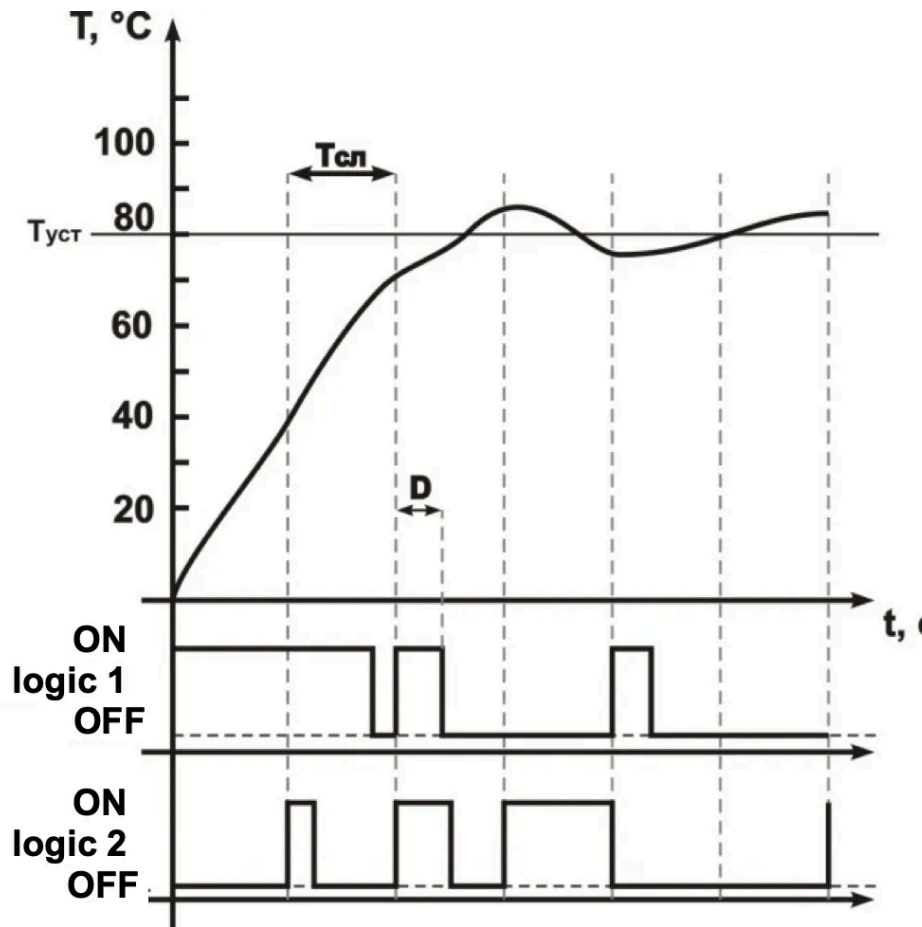

Figure 3.11 – Diagram of output relay action in PID regulation mode

⚠ Caution

The small value of Tcycle leads to often commutation and short life power contacts but the big value of Tcycle leads to quality loss regulation.

3.2.7 RS-485 Communication Interface

Using of interface is described in Appendix A.

4 Maintenance and Safety

4.1 Safety

Open terminals of the device carry dangerous voltage of up to 250 V. Any connections to the device and its maintenance operations must be performed only on de-energized device and executive units.

Ingress of moisture to the output terminals and the device inside electronic elements is not allowed. The use of the device in aggressive environments containing acids, alkali, oils, etc. is prohibited.

The device connection, adjustment and maintenance must be performed only by authorized personnel that is familiar with this manual.

4.2 Maintenance Schedule

Recommended maintenance schedule – semiannually.

Maintenance scheduled operations consist of visual observation, during which wiring connection to terminals is checked, frame and casing integrity check for cracking and chipping.

During maintenance operations, the safety precautions listed in chapter 4.1 must be followed.

5 Device Connection

5.1 Periphery Connections

5.1.1 General Instructions

Prepare cables for connecting the device to sensors, execution mechanisms and peripheral equipment, as well as to the power supply. To provide for the electric connections reliability it is recommended to use cables with copper stranded wires, the ends of which should be carefully cleaned and soldered prior to connecting. The wire core shall be cleared in such way, that its bare ends would not project beyond the terminals after connection to the device. The cable section must not exceed 2.5 mm².

5.1.2 Mounting Instructions Aimed at Electromagnetic Interference Reduction

When laying the “device-sensor” lines, they should be separated into an individual tract (or several tracts). The tracts shall be placed separately from the power cables, as well as from cables that produce high frequency and pulse interference.

Note

The tracts shall be planned in such manner, that the signal lines length is kept minimal.

5.1.3 Mounting Instructions Aimed at Reduction of the Power Circuit Interference

The device shall be connected to 220V 50Hz circuit feeder that is not connected with supplying power to heavy-duty industrial equipment. It is recommended to install in the peripheral supply line a feed switch providing disconnecting the device from the circuit, as well as 1A fuses.

5.2 Device Connection

The device shall be connected in accordance with the diagram on Figure 5.1, observing the listed below sequence:

A) Connect the device to power supply and execution units; B) Connect the “device-sensor” communication lines to the device inputs.

Danger

The device terminals for connecting power circuit and peripheral heavy-duty equipment are designed for max voltage of 250V. To avoid disruptive electric discharge or insulation arc-over it is prohibited to connect power sources with higher voltage than one mentioned to the device terminals.

5.3 Connecting Sensors (RTDs)

TR-101 devices employ a three-wire diagram for connecting RTDs (resistance temperature detectors). Two wires are connected to one of the RTD outputs, and the third wire is connected to the other RTD output (see Figure 5.1). Such diagram, provided that impedance of all three wires is equal, allows to compensate its impact onto the temperature measurement.

The resistance temperature detectors can be connected to the device under a two-wire diagram as well, but such arrangement does not provide for the connecting wiring impedance compensation which may lead to certain dependence of the device measurement from the wires temperature variation.

5.3.1 Connecting Sensors (RTDs) According to a Two-Wire Diagram

5.3.1.1 The RTDs (resistance temperature detectors) are connected to the device according to a two-wire diagram in case when a three-wire diagram cannot be used, for example, when TR-101 is installed within units equipped with earlier laid two-wire connection lines.

5.3.1.2 Please, mind that the device readings will depend on the "device-sensor" communication line wires impedance change, that takes place under influence of the outside air temperature. To compensate for the wires parasitic resistance, perform the following:

1. Before the operation start install a jumper between contacts 23 and 24 ((26 and 27), (29 and 30), (32 and 33)) of the terminal block, and connect the two-wire line immediately to contacts 22 and 23 ((25 and 26), (28 and 29), (31 and 32)).
2. Then connect a resistor box with accuracy rating not less than 0.05 (P321, for example) to the opposite ends of the "device-sensor" communication line, instead of the thermal element.
3. On the resistor box, set the value equal to the RTD resistance at temperature of 0 °C (50, 100, 500, 1000 Ohms, depending on the sensor type).
4. Energize the device and after 20-30 sec, by the digital display readings, define the value of the temperature deviation from 0 °C.
5. Set the Sh1 (Sh2, Sh3, Sh4) parameter value equal to the temperature deviation value, taken with the opposite sign.
6. Check the accuracy of the value assigned; to do it, without changing the resistance value on the resistor box, switch the device to the temperature measurement mode, and verify that its reading is equal to 0 ± 1 °C.
7. De-energize the device, disconnect the communication line from the resistor box and connect it to RTD.
8. After all these actions, the device is ready for further operation.

⚠ Caution

To avoid interference impact to the measurement part of the device, the “device-sensor” communication lines must be:

- made of screened cable of twisted pair (triple);
- have section of not less than 0.5 mm²;
- be reliably connected to the device terminals;
- the cable connection route must be separate from the high voltage cables and inductive load feeding cables.

⚠ Danger

THE DEVICE IS NOT INTENDED FOR THE LOAD COMMUTATION IN CASE OF SHORT CIRCUIT. THEREFORE THE DEVICE SHOULD BE OPERATED IN THE ELECTRICAL MAINS PROTECTED BY THE CIRCUIT BREAKER WITH INTERRUPTING CURRENT OF 16 A MAXIMUM OF CLASS B.

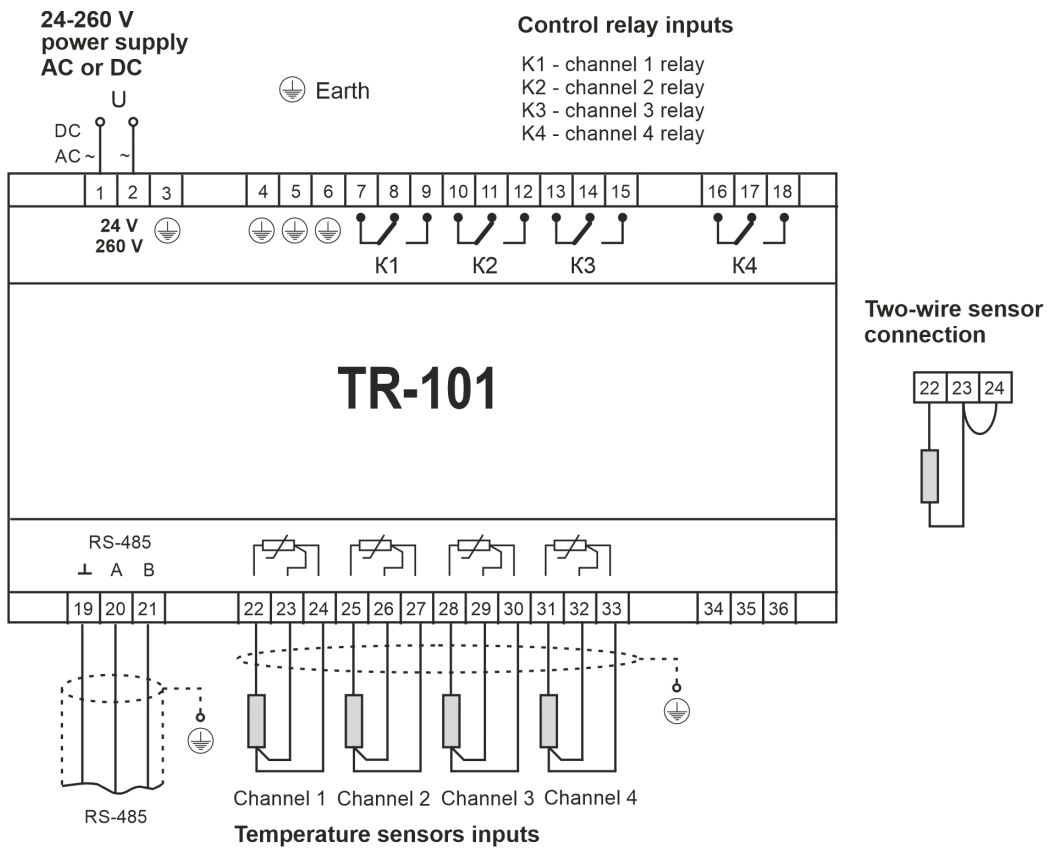

Figure 5.1 – TR-101 Connection Diagram

6 TR-101 Operation

6.1 General Information

6.1.1 When the device is powered on, all displays light up for 2 seconds. After that on the digital display the measured temperature for Channel 1 is shown. The device sequentially displays the temperature of the active channels with 4 sec interval.

6.1.2 In case of certain faults presence, the device displays the error code (Table 6.1).

Table 6.1 – Error Codes

Failure	Display	Description
Parameter error	ErP	Instead of the faulty parameter TR-101 loads the default value and continues to function normally
EEPROM failure	EEP	All relays are open
Sensor short circuit	FCC	The corresponding channel relay opens and "sensor failure" and "relay" lights begin to flicker
Sensor disconnection	F0C	The corresponding channel relay opens and "sensor failure" and "relay" lights begin to flicker

6.2 Output Relay Testing

The device gives an opportunity to test both all relays at once, or each relay independently; to test, perform the following:

- When in parameter edit mode, set the tSt parameter value according to Table 7.1 and press ENTER key; upon that, the display will show OFF message (which means that all relays that are being tested are currently in the normally open (de-energized) state), all LED lights will go off.
- Single pressing of ENTER key changes the status of the relays under testing:
 - OFF – the relays are in normally open (de-energized) state
 - On – the relays are in normally closed (energized) state
- To switch back to the menu press the MENU key. If no key is pressed during 20 sec the TR-101 device goes into the initial state.

7 Programming

7.1 General Information

Caution

During stay in program mode device doesn't make regulation but power output loading relay switches to mode OFF.

7.1.1 Programmable parameters are set by the user during programming session and are stored in device's nonvolatile memory.

The complete list of programmable parameter registers is given in Table 7.1.

Table 7.1 – Programmable Parameters

General Parameters

Address	Parameter	Mnemonic	Min/Max	Factory	Description
21	Sensor fault	Act	0/1	0	Loading relay state on sensor fault: 0 – OFF; 1 – ON

System Parameters

Address	Parameter	Mnemonic	Min/Max	Factory	Description
22	Indication mode	dSP	0/1	0	0 – sequential display (4 sec); 1 – manual view
23	Password	PAS**	000/999	000	000 – password off; any other value activates password prompt
24	Reset	rSt*	0/1	0	0 – do not reset; 1 – reset all to factory values
25	Relay Testing	tSt*	0/4	0	0 – all relays; 1-4 – test relay 1-4
26	Version	vEr*	–	53	Device version

RS-485 Parameters

Address	Parameter	Mnemonic	Min/Max	Factory	Description
27	Switching	rSA	0/2	0	0 – OFF; 1 – ON; 2 – Remote Control for Power Relays
28	Identifier	rSn	1/247	1	Device number (network address)
29	Bit rate	rSS	0/2	2	0 – 2400 bps; 1 – 4800 bps; 2 – 9600 bps
30	Timing	rSL	0/999	0	Delay time of response (×100 μs)

Channel 1 Parameters

Address	Parameter	Mnemonic	Min/Max	Factory	Description
31	Switching channel	ch1	0/3	1	0 – off; 1 – two-position; 2 – PID; 3 – PID auto tuning
32	Setting	SP1	-50/200 °C	100	Temperature setting (Tset)
33	Hysteresis	HS1	0/50 °C	1	Temperature hysteresis (HS)
34	Relay	rt1	0/1	0	0 – logic 1 (heater); 1 – logic 2 (cooler)
35	Proportional PID	P1	1/999 °C	40	PID Proportionality band (Xp)

Address	Parameter	Mnemonic	Min/Max	Factory	Description
36	Integral PID	i1	0/999 min	130	PID integral constant (τ_i)
37	Differential PID	d1	0/999 min	4	PID differential constant (τ_d)
38	Period	t1	60/999 s	60	Pulse-repetition interval of PLM (Tcycle)
39	Interval	L1	1/999 s	1	Minimal length of PLM
40	Characteristic shift	Sh1	-50/50 °C	0	Sensor characteristic shift (0 – disabled)
41	Characteristic slope	KU1	0.50/2.00	1.00	Sensor characteristic slope (Modbus: value x100)
42	Filter band	Fb1	0/50 °C	0	Digital filter band (0 – disabled)
43	Filter time	Ft1	0/60 s	2	Digital filter time constant (0 – disabled)
44	Sensor type	Ct1	0/16	1	See sensor type codes below

Channel 2 Parameters

Address	Parameter	Mnemonic	Min/Max	Factory	Description
45	Switching channel	ch2	0/3	1	0 – off; 1 – two-position; 2 – PID; 3 – PID auto tuning
46	Setting	SP2	-50/200 °C	100	Temperature setting (Tset)
47	Hysteresis	HS2	0/50 °C	1	Temperature hysteresis (HS)
48	Relay	rt2	0/1	0	0 – logic 1 (heater); 1 – logic 2 (cooler)
49	Proportional PID	P2	1/999 °C	40	PID Proportionality band (X_p)
50	Integral PID	i2	0/999 min	130	PID integral constant (τ_i)
51	Differential PID	d2	0/999 min	4	PID differential constant (τ_d)
52	Period	t2	60/999 s	60	Pulse-repetition interval of PLM (Tcycle)
53	Interval	L2	1/999 s	1	Minimal length of PLM
54	Characteristic shift	Sh2	-50/50 °C	0	Sensor characteristic shift (0 – disabled)

Address	Parameter	Mnemonic	Min/Max	Factory	Description
55	Characteristic slope	KU2	0.50/2.00	1.00	Sensor characteristic slope (Modbus: value x100)
56	Filter band	Fb2	0/50 °C	0	Digital filter band (0 – disabled)
57	Filter time	Ft2	0/60 s	2	Digital filter time constant (0 – disabled)
58	Sensor type	Ct2	0/16	1	See sensor type codes below

Channel 3 Parameters

Address	Parameter	Mnemonic	Min/Max	Factory	Description
59	Switching channel	ch3	0/3	1	0 – off; 1 – two-position; 2 – PID; 3 – PID auto tuning
60	Setting	SP3	-50/200 °C	100	Temperature setting (Tset)
61	Hysteresis	HS3	0/50 °C	1	Temperature hysteresis (HS)
62	Relay	rt3	0/1	0	0 – logic 1 (heater); 1 – logic 2 (cooler)
63	Proportional PID	P3	1/999 °C	40	PID Proportionality band (Xp)
64	Integral PID	i3	0/999 min	130	PID integral constant (τi)
65	Differential PID	d3	0/999 min	4	PID differential constant (τd)
66	Period	t3	60/999 s	60	Pulse-repetition interval of PLM (Tcycle)
67	Interval	L3	1/999 s	1	Minimal length of PLM
68	Characteristic shift	Sh3	-50/50 °C	0	Sensor characteristic shift (0 – disabled)
69	Characteristic slope	KU3	0.50/2.00	1.00	Sensor characteristic slope (Modbus: value x100)
70	Filter band	Fb3	0/50 °C	0	Digital filter band (0 – disabled)
71	Filter time	Ft3	0/60 s	2	Digital filter time constant (0 – disabled)
72	Sensor type	Ct3	0/16	1	See sensor type codes below

Channel 4 Parameters

Address	Parameter	Mnemonic	Min/Max	Factory	Description
73	Switching channel	ch4	0/3	1	0 – off; 1 – two-position; 2 – PID; 3 – PID auto tuning
74	Setting	SP4	-50/200 °C	100	Temperature setting (Tset)
75	Hysteresis	HS4	0/50 °C	1	Temperature hysteresis (HS)
76	Relay	rt4	0/1	0	0 – logic 1 (heater); 1 – logic 2 (cooler)
77	Proportional PID	P4	1/999 °C	40	PID Proportionality band (Xp)
78	Integral PID	i4	0/999 min	130	PID integral constant (ti)
79	Differential PID	d4	0/999 min	4	PID differential constant (td)
80	Period	t4	60/999 s	60	Pulse-repetition interval of PLM (Tcycle)
81	Interval	L4	1/999 s	1	Minimal length of PLM
82	Characteristic shift	Sh4	-50/50 °C	0	Sensor characteristic shift (0 – disabled)
83	Characteristic slope	KU4	0.50/2.00	1.00	Sensor characteristic slope (Modbus: value x100)
84	Filter band	Fb4	0/50 °C	0	Digital filter band (0 – disabled)
85	Filter time	Ft4	0/60 s	2	Digital filter time constant (0 – disabled)
86	Sensor type	Ct4	0/16	1	See sensor type codes below

Notes:

- * Parameter available only for reading
- ** Remote access to computer is forbidden

Sensor Type Codes

Code	Sensor	Code	Sensor	Code	Sensor
0	Pt50	6	Ni100	12	Pt'500
1	Pt100	7	Ni120	13	Pt'1000
2	Pt500	8	Ni500	14	Cu'50
3	Pt1000	9	Ni1000	15	Cu'100

Code	Sensor	Code	Sensor	Code	Sensor
4	Cu50	10	Pt'50	16	PTC1000
5	Cu100	11	Pt'100		

PID Coefficients

Commercial units of PID coefficients are settled as a result of following object characteristic:

- The heating is performed from 0°C to 100°C
- Rate of heating is 1°C per minute
- Yield of rated temperature takes place by 70% of power heating in such a way excess of power is 30%

7.1.2 Viewing Parameters

To view parameters, press MENU key once, the display will show parameter 1 from Table 7.1. Scroll parameters with ▲▼, parameter view – press key ENTER, passage back to menu – press key MENU.

7.1.3 Editing Parameters

To edit parameters, press and hold MENU key for 7 seconds, at that:

1. If a password had been set up, enter it. Use ▲▼ keys to change current position, use ENTER key to move to nExt position, use MENU key to confirm the password. Cancel password prompt – if no key has been pressed during 20 sec the TR-101 device returns to the initial state.
2. If the entered password is correct, the "Setting mode" LED will light (Figure 3.2, item 8), and the display will present the first parameter from Table 7.1.
3. If the password entered is incorrect, the TR-101 will return to its initial state.
4. If PAS has been set to "0", password prompt will not be activated. "Setting mode" LED will light (Figure 3.2, item 8), and the display will present the first parameter from Table 7.1.

Use ▲▼ keys to toggle parameters, use ENTER key to store parameter and return to menu, to return to menu without storing parameter, press MENU key. If no key is pressed during 20 sec the device goes into the initial state.

7.1.4 Reset to Factory Settings

Method 1: In the parameter edit mode (p. 7.1.3) set rSt parameter to 1 and press ENTER key, after that, the device will perform resetting to default factory set parameters. Password will not be reset in this case.

Method 2: Energize the device while pressing down ▲▼ keys and hold them pressed for over 2 seconds, at that the display will show nAU message; release the keys. De-energize the device. All factory settings including the password have been restored (password is off).

7.2 Programming Sequence

7.2.1 Setting Up Measurement Entry Parameters

7.2.1.1 Enter the Ct1 (Ct2, Ct3, Ct4) parameter value in accordance with the sensor type (Table 1, Table 7.1).

7.2.1.2 Measurement Characteristic Adjustment

The measurement adjustment procedure performed by the device is described in paragraph 3.2.3. The device performs measurement adjustment after the necessary values for parameters Sh – sensor measurement characteristic shift and KU – sensor measurement characteristic slope, have been set.

- Sh parameter can be modified within boundaries from -50 to +50 °C
- KU parameter can be modified within boundaries from 0.50 to 2.00

Note

1. The necessity of measurement accuracy adjustment becomes clear after the sensors and device have been verified.
2. When thermal element is connected under a two-wire diagram, the Sh parameter must be entered. The Sh parameter value definition is performed according to methodology described in 5.3.1.

7.2.2 Setting Up Digital Filter Parameters

The digital filter operation is described in paragraph 3.2.4.

The measurement digital filter setting up is performed by specifying two parameters values:

- Fb – digital filter band
- Ft – digital filter time constant

The Ft value can be set within limits from 0 to 60 sec; when Ft = 0 filtration by way of exponential smoothing is unavailable.

The Fb value is set within range from 0 to 200 °C; when Fb = 0 the “single interference termination” is off.

7.2.3 Setting Up Relay Control Method Parameters

For a specific regulation system, the control method has to be selected by means of setting corresponding values to rt1 (rt2, rt3, rt4) parameter:

- 0 – logic 1 (heater)
- 1 – logic 2 (cooler)

7.2.4 Setting Control Modes

The device can function in one of the two modes: the two-position control and PID-control.

The proper mode is set by specifying a proper value for ch1 (ch2, ch3, ch4) parameter:

- 0 – OFF
- 1 – two-position control
- 2 – PID control
- 3 – Automatic adjustment of PID regulator

The two-position control and PID control operation is described in paragraphs 3.2.5 and 3.2.6.

The two-position controller hysteresis HS (°C) is set under HS1 (HS2, HS3, HS4) parameter, see 3.2.5; the parameter may be modified within range from 0 to +50 °C.

7.2.5 PID Regulator Adjustment

7.2.5.1 General Concept

PID regulator operation is described at p. 3.2.6.

For adjustment of PID regulator needed attend following actions:

1. Set value of regulator setting SP1 (SP2, SP3, SP4)
2. Set parameters of pulse-length modulation (PLM) regulation:
 - t – pulse repetition period T_{cycle}
 - L – minimal pulse length
3. Set parameters of PID regulation:
 - P – Proportionality band of regulator X_p
 - i – Reaction time of integration τ_i
 - d – Reaction time of differentiator τ_d

Option setting t_1 (t_2 , t_3 , t_4) set in seconds from 60 to 999.

Option setting L_1 (L_2 , L_3 , L_4) set in seconds from 1 to 999.

Option setting P_1 (P_2 , P_3 , P_4) set in °C from 1 to 999.

Option setting i_1 (i_2 , i_3 , i_4) set in minutes from 0 to 999. For $i = 0$ device works as PD regulator.

Option setting d_1 (d_2 , d_3 , d_4) set in minutes from 0 to 999. For $d = 0$ device works as PI regulator.

For $i = 0$ and $d = 0$ device works as P regulator.

Considering that at each individual scheme there are non-periodic External actions of different characters, all coefficients in above shown formulas can change for getting optimal behavior in positive conditions.

Selected parameters for superfine temperature maintenance in steady-state may happen totally unacceptable for suppression transient phenomena for External action or on-exit onto mode.

As well as alternatively.

For another thing in the course of operation controlled plant characteristic regulation can change very much. Like for operational changes and in time.

Usually calculated values require repeated correcting and selection. And changing single parameter involves necessity correcting other.

7.2.5.2 Automatic Adjustment of PID Regulator

This mode designed to autodetection initial approximate values of PID coefficients τ_i , τ_d and X_p when operated at concrete scheme.

Automatic tuning is recommended to lead by start and system debugging.

7.2.5.2.1 Enter to program mode (see p. 7.1.3).

7.2.5.2.2 Define SP (Tset) like setting value which in future will be supported by device.

If necessary fix PLM pulses repetition period and minimal PLM pulse length, parameters t1 and L1.

Factory settings are t1 = 60 seconds, L1 = 1 second.

7.2.5.2.3 Define parameter ch1 = 3 (ch2, ch3, ch4).

After pressing key ENTER, at display device will appear blinking caption Pid with number display device for 10 seconds (the time can change depending on fixed time filter Ft1, Ft2, Ft3, Ft4).

On the morrow of time regulator will give continuous output limit and at display device will appear current temperature dotted in low order position "xxx".

Whereby output relay of loading will be power on till will not be reach the volume of temperature like SP (Tset).

After switching off loading relay (period I, point B) sometime the temperature mechanically will increase further.

As soon as the control temperature will come down below SP (Tset), process automatic tuning will finish (point G at Figure 7.1) and display device will show continuous lettering Pid.

TR-101 calculates coefficient of PID regulator: band proportionality, characteristic time of integration, characteristic time of differentiator.

After finishing automatic tuning needed press key MENU and switch device to program mode in which is possible to look and correct received coefficients value.

The coefficients were received as a result of "Automatic tuning PID" are not optimal and work for preliminary analysis.

Note

For cancellation started mode of automatic tuning needed hold the MENU key for seven seconds.

7.2.5.3 PID Regulator Manual Setting

Below mentioned method allows defining approximate generic parameters of regulator.

7.2.5.3.1 Enter to program mode.

7.2.5.3.2 If necessary, fix **PLM** pulses repetition period and minimal PLM pulse length, parameters t and L.

Factory settings are t = 60 seconds, L = 1 second.

7.2.5.3.3 Fix the value equal to zero for i (τ_i), d (τ_d) and P (X_p). Fix SP (Tset) value equal to temperature setting value which will be supported by device in future.

After passage to mode regulation (at the end of 20 seconds the device automatically passes into mode regulation) output relay of loading will be power on till fail to reach regulation temperature (setting limit) Tset (period I, point B at Figure 7.1).

7.2.5.3.4 Take measure t_1 – time from the moment of temperature increase to 10% (point A at Figure 7.1) and to the moment of temperature increase to 63% from the range $T_{set} - T_{max}$ (point B at Figure 7.1).

7.2.5.3.6 Take measure of maximum value overshoot between points B and G (E_{max} , Figure 7.1).

7.2.5.3.7 Fix the value $X_p = 2 \times E_{max}$ (period II at Figure 7.1).

Make sure that for datum value X_p does not absent achievement of setting value T_{set} . Otherwise necessary increase the value X_p .

If the value of $X_p = 2 \times E_{max}$ and the difference between steady-state temperature and setting value is too much, then need to diminish X_p .

7.2.5.3.8 Fix the value $\tau_i = 2.4 \times t_1$. Make sure that given value τ_i not appear temperature vibration around setting value (period III). For decreasing vibration is necessary increase value τ_i , for increasing delivery speed necessary diminish value τ_i .

7.2.5.3.9 Fix the value τ_d equal to $[0.1; 0.2; 0.3; 0.4] \times t_{obj}$.

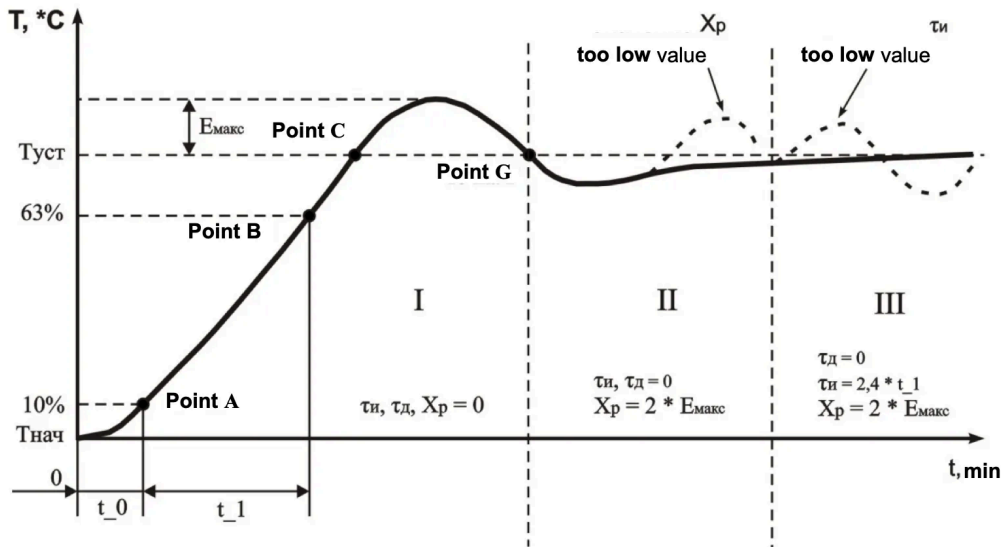

Figure 7.1 – PID regulator manual tuning diagram

8 Service Life, Shelf Life and Manufacturer Warranty

8.1 The unit service life is 10 years. Upon expiration of the service life you should contact the Manufacturer.

8.2 Shelf life is 3 years.

8.3 Warranty period of the unit operation is 5 years from the date of sale.

During the warranty period the Manufacturer is responsible for free repair of the unit, if the Consumer has complied with the requirements of this Operating Manual.

 **Danger**

IF THE UNIT HAS BEEN OPERATED WITH VIOLATION OF THE REQUIREMENTS OF THIS OPERATION MANUAL, BUYER WILL FORFEIT THE RIGHT TO WARRANTY SERVICE.

8.4 Warranty service is performed at the place of purchase or by the Manufacturer of the product.

8.5 Post-warranty service is performed by the Manufacturer at current rates.

8.6 Before sending for repair, the unit should be packed in the original or other packaging excluding mechanical damage.

9 Storage and Shipping Conditions

The device in manufacturer package should be stored in enclosed rooms at -45 to +60 °C and exposed to no more than 80% of relative humidity when there are no fumes in the air that exert a deleterious effect on package and the device material. The Buyer must provide the protection of the device against mechanical damages in transit.

For all questions, please contact the Manufacturer:

"Novatek-Electro" Ltd.

www.novatek-electro.com

59, Mykhailo Boltenko (Admiral Lazarev) str., Odesa, Ukraine, 65007

Tel: +38 (067) 565 37 68 +38 (050) 359 39 11 +38 (063) 301 30 40

VN251029

Appendix A: RS-485 Communication Interface

1 General Information

The communication interface is employed to connect the TR-101 device to RS-485 network. The device utilization within RS-485 network allows for the following functions:

- collecting data of measured temperatures within SCADA system;
- setting device parameters with use of configuration software;
- remote control of the channels output relays.

RS-485 as an interface standard has found extensive industrial application; it provides for establishing networks with node count of up to 247 and data transfer at distance of up to 1200 m. With use of duplicators, the number of nodes and the transmission distance can be increased.

All network devices are connected in a serial bus (Figure A1). To maintain the reliable operation of transmitters/receivers and to eliminate interference impact, the communication line ends must be equipped with a terminating resistor of impedance $R_{\text{corn}} = 120 \text{ Ohm}$ that is connected immediately to the device terminals (see Figure A1).

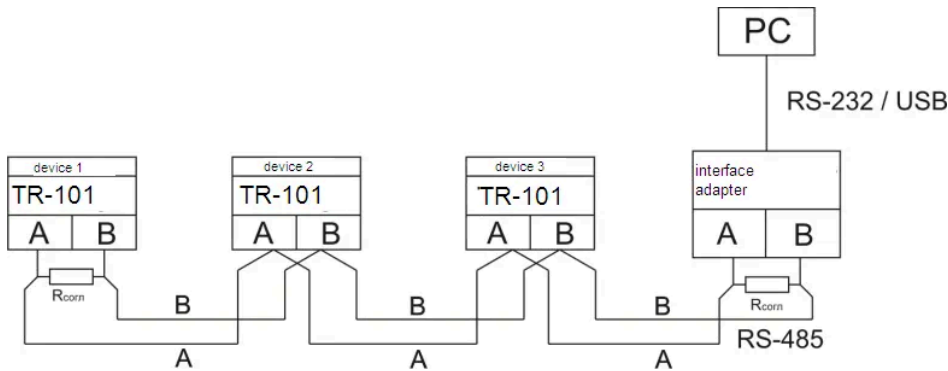

Figure A1 – RS-485 Network Connection Diagram

Note

The device is connected to a PC via RS-485 / RS-232 or RS-485 / USB interface adapter.

The data exchange may take place at one of the following bitrates: 2400, 4800, 9600 bps.

2 Remote Control for Power Relays

By installation the value $r_{SA} = 2$ (Table 7.1) device will be switched to the mode of remote management power relay. Control registers are shown in Table A2.

If the channel working with two level action and labeled to control register value 0 or 1 is possible to switch on or switch off prorated power relay.

If the channel working with PID regulation and labeled to control register value 0 or 100 is possible to manage capacity plug into correspondent relay (pos. 3.2.6.6 of manual).

If the mode "Remote management of power relay" is switched on TR-101 continuous working in usual mode.

Exception is the fact that management of power relay is passed to operator.

3 Data Exchange Adjustment Through Interface RS-485

Data exchange adjustment is realized by parameters:

Parameter	Mnemonic	Description
Switching	rSA	Set switching on (switching off) RS-485 and the mode of remote management
Identifier	rSn	Device base address (1...247)
Bit rate	rSS	Rate of exchange data online (2400, 4800, 9600 bit/s)
Timing	rSL	Time delay of the packet answer 0-99.9 ms

Device TR-101 has following fixed exchange parameters not shown at the indicator:

- Quantity Stop-bit: 2
- Length of a data word: 8
- Parity check: not

Caution

New option exchange values come into effect only after device restarting or restarting at RS-485.

4 Data Exchange Through Interface RS-485

4.1 Connection Setup

Working through interface RS-485 it should be done relevant connection (p. 1 of Appendix A) and set the value of net parameters (p. 3 of Appendix A).

4.2 Network Master

For organization data exchange online through interface RS-485 necessary have net Master. The main function of this device is to activate data exchange between sender and recipient. TR-101 may work at Slave mode by ModBus RTU protocol.

4.3 ModBus Protocol

ModBus is the open network protocol that was developed by company Modicon. Protocol description available at website www.modbus.org.

Register addresses of program parameters are shown in Table 7.1 of the manual.

Check list of supported functions (Modbus) is shown in Table A1.

Additional registers and their functions are shown in Table A2.

Supported Modbus Functions

Table A1 – Supported Modbus Functions

Function (hex)	Sub-function	Description	Note
0x03	—	Receiving value of one or several registers	max. 125
0x06	—	Recording one value to the register	—
0x08	0x00	Return query data	Diagnostics
0x08	0x01	Communication options restart	Diagnostics
0x08	0x04	Setting up "listen only" mode	Diagnostics

Additional Registers

Table A2 – Additional Modbus Registers

Device Identification

Address (dec)	Name	Description	Note
0	Device ID (MSB)	TR-101 – 0x0002	ID
1	Device ID (LSB)	Firmware version - v53	Version

Status Register (Address 2)

Bit	Description
bit 0	0 – no emergency; 1 – Emergency (emergency code in register)
bit 1	0 – relay of channel 1 is switched off; 1 – relay of channel 1 is switched on
bit 2	0 – relay of channel 2 is switched off; 1 – relay of channel 2 is switched on
bit 3	0 – relay of channel 3 is switched off; 1 – relay of channel 3 is switched on
bit 4	0 – relay of channel 4 is switched off; 1 – relay of channel 4 is switched on
bit 5 – bit 15	reserved

Emergency Register (Address 3)

Bit	Description	Display
bit 0	0 – Not emergency; 1 – EEPROM rejection	EEP
bit 1	0 – Not emergency; 1 – parameter mistake	ErP

Bit	Description	Display
bit 2	0 – Not emergency; 1 – sensor 1 short circuit	FCC
bit 3	0 – Not emergency; 1 – sensor 2 short circuit	FCC
bit 4	0 – Not emergency; 1 – sensor 3 short circuit	FCC
bit 5	0 – Not emergency; 1 – sensor 4 short circuit	FCC
bit 6	0 – Not emergency; 1 – sensor 1 disconnection	F0C
bit 7	0 – Not emergency; 1 – sensor 2 disconnection	F0C
bit 8	0 – Not emergency; 1 – sensor 3 disconnection	F0C
bit 9	0 – Not emergency; 1 – sensor 4 disconnection	F0C
bit 10 – bit 15	reserved	

Temperature Registers

Address (dec)	Name
4	Sensor temperature 1
5	Sensor temperature 2
6	Sensor temperature 3
7	Sensor temperature 4

Relay Control Registers

Address (dec)	Name	When ch = 1 (Two-position)	When ch = 2 (PID)
8	Register of relay control 1	0 – relay OFF; 1 – relay ON	0 – capacity 0%; 100 – capacity 100%
9	Register of relay control 2	0 – relay OFF; 1 – relay ON	0 – capacity 0%; 100 – capacity 100%
10	Register of relay control 3	0 – relay OFF; 1 – relay ON	0 – capacity 0%; 100 – capacity 100%
11	Register of relay control 4	0 – relay OFF; 1 – relay ON	0 – capacity 0%; 100 – capacity 100%

Reserved Registers

Address (dec)	Description
12-20	Registers from 12 to 20 are reserved (equal to zero always)

Appendix B: Device Adjustment

1 General Instructions

Adjustment of instrument must be done by qualifying specialists of metrological service if the measurement errors of input parameters are more than settled value.

Before this operation necessary to check parameter set value Sh1 (Sh2, Sh3, Sh4) - "characteristic shift" and fix it equal to zero.

2 Adjustment of Instrument TR-101

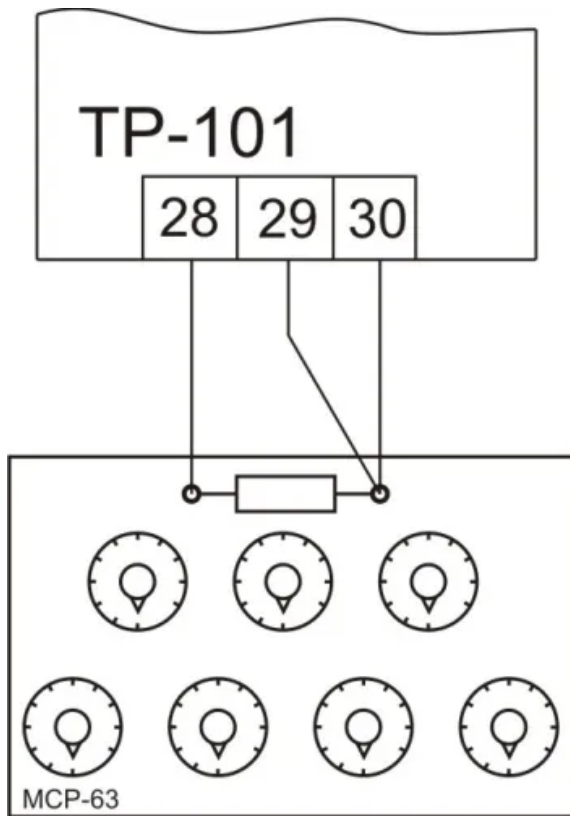

Figure B.1 – TR-101 Adjustment Setup

2.1 Wire Resistance Requirements

Resistance of wires should be equal in a line to each other and everyone should not exceed size 15 Ohm.

2.2 Resistance Box Connection

Plug into device input resistance box (instead of sensor) with accuracy class at least 0.05 (for example MSR-63) on three wire line (Figure B.1).

Fix at resistance box the following values depending on sensor type:

Sensor Type	Resistance Value (Ohm)
Pt50, Cu50	R = 50.00
Pt100, Cu100, Ni100	R = 100.00
Ni120	R = 120.00
Pt500, Ni500	R = 500.00
Pt1000, Ni1000	R = 1000.00
PTC1000 (EKS111)	R = 807.00

2.3 Verification Procedure

1. Power on TR-101
2. After 20-30 seconds make adjustment of device
3. Be sure that the temperature value for resistance 50, 100, 120, 500, 807, 1000 is equal to 0 °C
4. The pink limit of absolute accuracy is ± 1 °C

2.4 Characteristic Shift Adjustment

Fix parameter value Sh1 (Sh2, Sh3, Sh4) equivalent to temperature deviation but taken with opposite sign.

Test accuracy of settled value: without changing the resistance, wait till the device passes into temperature mode and be sure that its indications are 0 ± 1 °C.