



Novatek-Electro EM-483 Documentation

<https://www.overvis.com/docs/uk/em-483/>

2026-03-30

Table of Contents

1. Novatek-Electro EM-483
2. EM-483 Operating Manual
3. Appendix A: Connecting to the Server
4. Appendix B: Web Interfaces
5. Appendix C: Modbus Registers

Novatek-Electro EM-483



EM-483 — це мікропроцесорний конвертер протоколів виробництва NOVATEK-ELECTRO LTD. Він забезпечує обмін даними через мережі Ethernet 10BASE-T та 100BASE-T з обладнанням, оснащеним інтерфейсом RS-485.

 **Доступна повна документація**

Переглянути всю документацію на одній сторінці – Ідеально для друку або читання офлайн

Ключові особливості

- Гнучка адресація Ethernet (перевизначення MAC-адреси, статична або динамічна IP-адреса)
- Захист доступу через мережу Ethernet (пароль режиму конфігурації, фільтр IP-адрес)
- Різні режими обміну через мережу MODBUS (RTU або ASCII, перевірка парності)
- Підтримка до 5 віддалених серверів MODBUS TCP
- Тунельний режим для протоколів, відмінних від MODBUS

Документація

- **Інструкція з експлуатації** – Повні інструкції з експлуатації та конфігурації

Технічна довідка

- **Додаток А: Підключення до сервера** – Підключення до Overvis та інших серверів
- **Додаток В: Веб-інтерфейси** – Довідка HTTP API
- **Додаток С: Регістри MODBUS** – Повна довідка реєстрів

Додаткові ресурси

- Сторінка продукту EM-483 – Повна інформація про продукт та специфікації
- Документація на одній сторінці – Повна документація на одній сторінці для друку
- Повна інструкція EM-483 (PDF) – Повна інструкція з експлуатації

Підтримка

- **Центр підтримки:** Відвідайте наш Центр підтримки
- **Повідомити про проблему:** Надішліть заявку

EM-483 Operating Manual



The Protocol Converter EM-483 (hereinafter referred to as "Product", "EM-483") is a microprocessor device manufactured by NOVATEK-ELECTRO LTD.

The product is designed for data exchange over a 10BASE-T and 100BASE-T Ethernet network with equipment supplied with an RS-485 interface.

The EM-483 provides for MODBUS server functions to connect MODBUS clients over an Ethernet network. The product redirects MODBUS requests from clients to devices on the MODBUS network and returns responses from the devices to the clients.

EM-483 can also be used in tunnel mode for direct data transmission between clients and RS-485 devices using protocols other than MODBUS.

Dear Customer

Company NOVATEK-ELECTRO LTD thanks you for purchasing our device. You will be able to use properly the device after carefully studying the Operating Manual. Keep the Operating Manual throughout the service life of the device.

The EM-483 provides for:

- Flexible Ethernet addressing (MAC address override, and static or dynamic IP address);
- Protection of access via the Ethernet network (configuration mode password, IP address filter for configuration or for connection to the MODBUS network);
- Various modes of exchange over the MODBUS network (RTU or ASCII, with parity checking for even and odd or without checking, a wide range of transmission rates, and configurable delay).

Overall and Mounting Dimensions

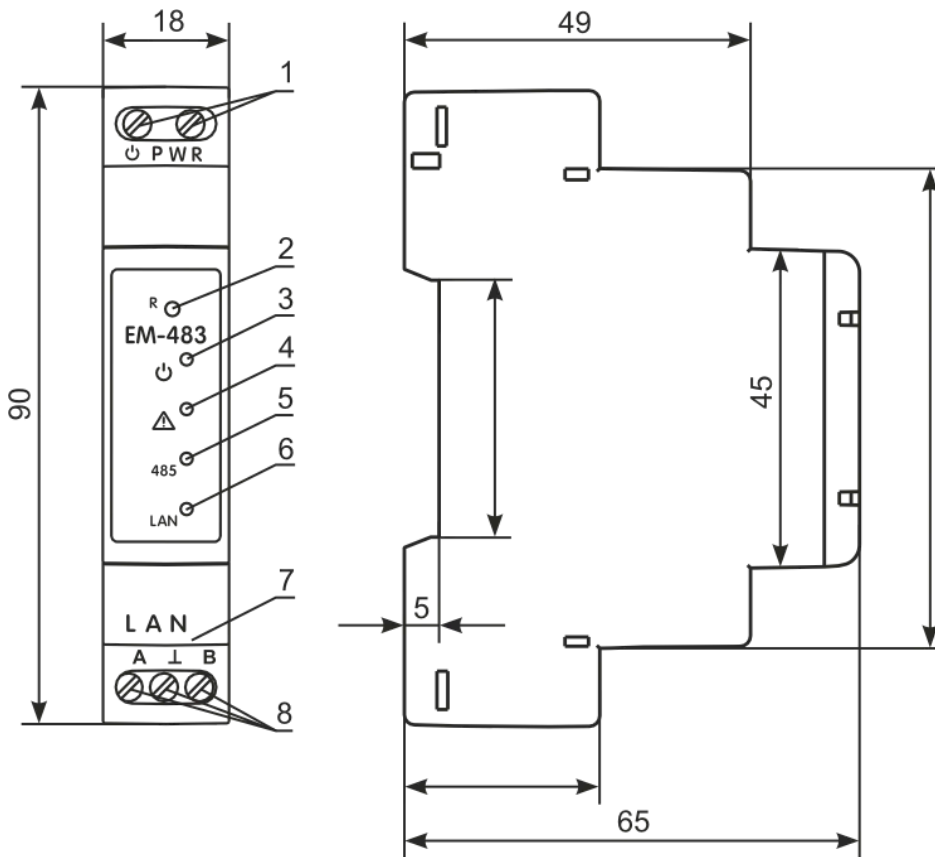

Figure 1 – Overall and mounting dimensions and controls

1. The «**PWR**» terminals are designed to connect a power supply from 7 to 30 V DC or AC.
2. The reset button «**R**» is used to restart the product or to reset the parameters to the factory values.
3. The Indicator «**=**» lights up when there is power supply voltage.
4. The Indicator «**Δ**» warns about errors (including those in the format of received data packets).
5. The Indicator «**485**» is On when RS-485 transmission is pending, blinking when RS-485 communication is in progress.
6. The Indicator «**LAN**» lights up when connecting with the Ethernet network; it blinks in the course of exchange over the Ethernet network.
7. Connector for Ethernet connection.
8. Terminals «**A**», «**⊥**» and «**B**» are used for connecting to the RS-485 bus.

Firmware Versions

Version	Date Issued	Remarks
3	14.07.2020	Demo version
4	09.02.2021	The number of remote MODBUS TCP servers is increased to 5; RS-485 communication stability at minimum speeds improved
6	09.04.2024	Added ability to remotely update firmware; Added tunnel mode for non-MODBUS transmissions

Terms and Abbreviations

- **Firmware** – the firmware of the product that gets started up when the power is applied
- **Indicator** – single LED indicator
- **Client** – a device that accesses another device (server) with a request to perform certain functions
- **Packet** – a block of data for transmission between devices
- **Server** – a device that performs certain functions at the request of other devices
- **Ethernet** – a standard for packet-based network communication between devices (such as personal computers) used for wired local area networks
- **HTTP** – a protocol for transmitting Web pages and other data using the “client-server” technology
- **IPv4 (address)** – a four-byte node address, that is unique within a single network that operates over the IP protocol
- **MAC-48 (address)** – a six-byte address used in network transmissions to identify devices. As a rule, it has a globally unique value
- **RS-485/EIA-485** – a physical layer standard for an asynchronous interface used for transmission over a twisted pair of wires
- **TCP/IP** – a standard, a set of protocols for data transmission on networks with delivery control

Operation Conditions

The product is intended for operation in the following conditions:

- Ambient temperature: from minus 35 to +55 °C
- Atmospheric pressure: from 84 to 106.7 kPa
- Relative humidity (at temperature of +25 °C): 30 ... 80 %

Caution

If the temperature of the product after transportation or storage differs from the ambient temperature at which it is supposed to be operated, then before connecting to the mains keep the product under the operating conditions within two hours (because of condensation may be on the product elements).

ATTENTION

The product is not intended for operation in the following conditions:

- Significant vibration and shocks
- High humidity
- Aggressive environment with content in the air of acids, alkalis, etc., as well as severe contaminations (grease, oil, dust, etc.)

Technical Specifications

Parameter	Value
DC power supply voltage	7 – 30 V
Ethernet communication interface	10BASE-T/100BASE-T (twisted pair)
Supported Ethernet network protocols	MODBUS TCP, HTTP
Maximum number of connections via MODBUS TCP protocol	4
Embedded servers	MODBUS-server, HTTP-server
MODBUS network exchange standard	RS-485
Supported MODBUS network protocols	MODBUS RTU, MODBUS ASCII
Maximum number of devices connected to RS-485 (with input current of 1 mA)	32
Maximum number of devices connected to RS-485 (with input current of 0.125 mA)	256
Indication	LED
Power-on standby time	≤ 1 s
Output short-circuit current of the RS-485 driver (limit at the bus voltage of 12 V)	200 mA
Power consumption	1.5 W
Weight	≤ 0.08 kg
Overall dimensions, H×B×L	90 × 65 × 18 mm
The Product designation	Switchgear and control equipment
Rated operating condition	Continuous
Conductor cross-section for connecting to terminals	0.3 – 2.5 mm ²

Parameter	Value
Tightening torque of the terminal screws of input contacts	0.4 N·m
Protection class rating of the product	IP 20
Electric shock protection class	III
Climatic design version	NF 3.1
Overvoltage category	II
Permissible degree of contamination	II
Insulation rated voltage	450 V
Rated pulse withstand voltage	2.5 kV
Rated galvanic isolation voltage between power supply terminals and RS-485 terminals	1.5 kV
Rated galvanic isolation voltage between power supply terminals and Ethernet terminals	1.5 kV
Installation (mounting)	DIN rail 35 mm

The Product remains functional at any position in space.

Case material: self-extinguishing plastic.

The product meets the requirements of the following: EN 60947-1; EN 60947-6-2; EN 55011; EN 61000-4-2.

Harmful substances in an amount exceeding the maximum permissible concentrations are absent.

Connection

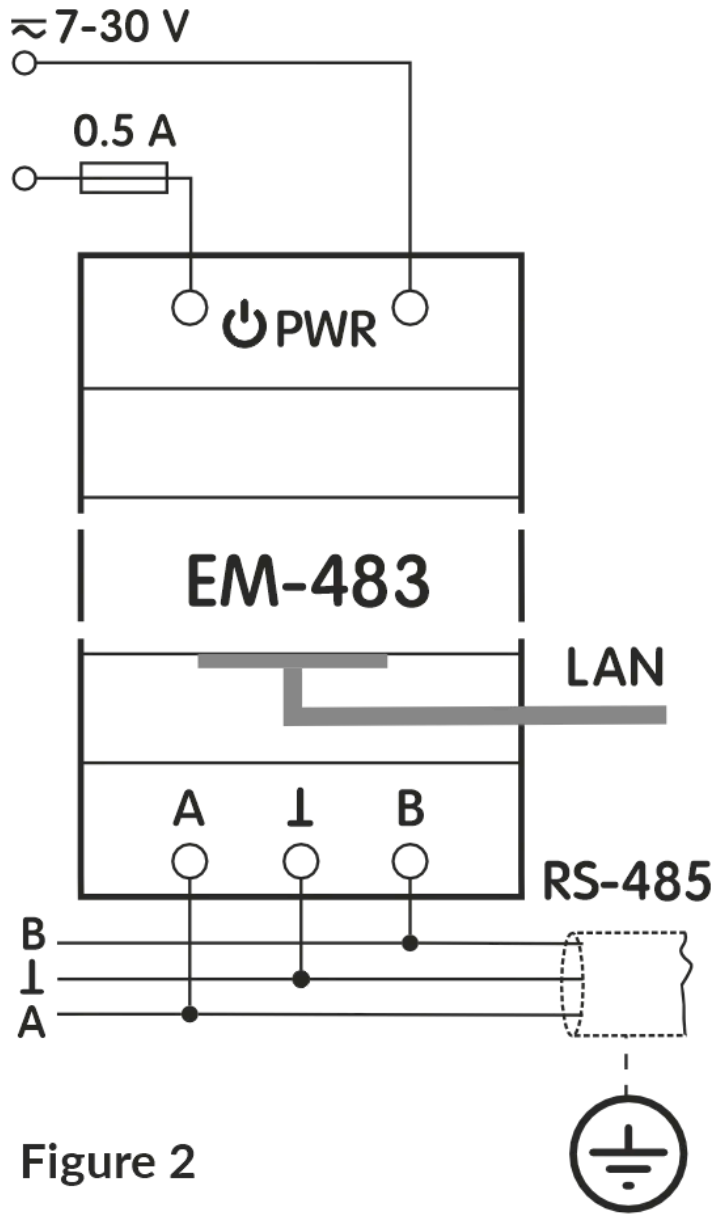

Figure 2

Figure 2 – Connection diagram

⚠ ATTENTION

ALL CONNECTIONS MUST BE PERFORMED WHEN THE PRODUCT IS DE-ENERGIZED.

Error when performing the installation works may damage the product and connected devices.

For a reliable contact, tighten the terminal screws with the force 0.4 N·m.

To ensure the reliability of electrical connections, use flexible (stranded) wires, the ends of which must be stripped of insulation by 5 ± 0.5 mm and compressed with bushing tips. It is recommended to use a wire with a cross section of at least

1 mm².

When connecting to the RS-485 bus, use a twisted pair cable. Cat. 1 or higher. A shielded grounded cable is recommended.

When fixing the wires, avoid mechanical damage, twisting or wearing down the insulation of the wires.

Note

To improve the performance of the Product, it is recommended to install the protective guard F1 (fuse insert) or its equivalent in the EM-483 power supply circuit at a current of 0.5 A.

The connection of EM-483 is made according to the scheme shown in Figure 2, in the following order:

1. Connect the connection cable to the RS-485 bus (Cat 1 twisted pair cable) to terminals «A», «L», «B» and to the RS-485 bus (or directly to the device with the RS-485 interface).

Note

Contact "A" serves for transmitting a non-inverted signal, and contact "B" – for an inverted signal.

2. Connect the Ethernet connection cable (Cat.5 or higher twisted pair cable with 8P8C/RJ45 connector) to the «LAN» connector and Ethernet network.
3. Connect the power supply to the «= PWR» power connector.

Operation

A 32-bit RISC processor with ARM architecture routes data between a MODBUS RTU/ASCII network (RS-485) and the Ethernet network (10BASE-T/100BASE-T). The speed and availability of direct memory access channels allow you to operate with high-speed data streams. The indicators indicate the status of the connections and the data flow over the MODBUS and Ethernet networks. The «R» button allows you to restart the EM-483 without disconnecting it from the network, or reset the settings to factory values.

The product is equipped with a memory for storing settings. Each product receives a globally unique MAC address during manufacturing and can connect to local networks that have a secure Internet connection.

Using the Product

After power is applied, the «△» and «485» indicators light up, and EM-483 initializes the transceivers. After that, both lights go out for 0.5 seconds, and the product starts performing server functions (the connection to the Ethernet network may take longer depending on the settings of the product and other devices connected to the network).

IMPORTANT

IF THE «△» INDICATOR IS CONSTANTLY LIT IN RED OR FLASHES PERIODICALLY, AFTER SWITCHING ON THE EM-483, CONTACT THE PLACE OF PURCHASE OR THE MANUFACTURER OF THE PRODUCT.

The EM-483 is waiting for an Ethernet connection. If the «LAN» indicator lights up, the network connection has been successful. The flashing «LAN» indicator shows that data is passing through the network.

Operation of EM-483 over the HTTP Protocol

EM-483 is waiting for an HTTP Ethernet connection to port 80. Connection from a PC can be made using a WEB browser.

When the client is connected to port 80, the product expects requests from the client to receive HTML pages. Parameters can be specified in the request. In response to the correct request, the parameters are processed, and the text of the selected page is transmitted to the client in HTML format (or in JSON or XML format for API requests, see Appendix B - WEB Interfaces). If the request does not specify an existing page, the title page will be returned. After the page is passed, the product disconnects the client and waits for the connection again.

Operation of EM-483 via the MODBUS Protocol

During operation, EM-483 is waiting for an Ethernet connection over the MODBUS TCP protocol to port 502. The MODBUS TCP connection port can be changed by the user. The connection from a PC can be made using any programs – MODBUS TCP clients. The application «MODBUS TCP client» is available for download on the manufacturer's website www.novatek-electro.com in the section «Software». An additional port for MODBUS RTU or MODBUS ASCII connections over TCP can also be specified in the settings.

When requesting a client connection to a MODBUS port, EM-483 checks the list of available connections. If all connections are busy, the connection is rejected; otherwise, it is added to the internal list of serviced clients (no more than four clients).

EM-483 is waiting for a MODBUS request:

- from the client, if the connection is established from the latter;
- from the master device via the MODBUS network, in the mode of the slave via the RS-485-interface;
- from the data collection server, when connected to it (see Appendix A - Connecting to the Server).

When a request is received from a client, it is analyzed and, depending on the code of the requested function and the current rights of the client, it is either processed or blocked. When blocking a request, EM-483 can generate and transmit to the client a user-specified MODBUS exception code (by default, code 1). The client's rights are determined by the passwords entered after the connection.

If the request is addressed to EM-483, the product does not redirect the request, but processes it and transmits the response to the client.

In the master mode via the RS-485 interface, requests to other devices are redirected to the MODBUS network, and a response is expected from the device in the MODBUS network – the «485» indicator lights up. If the data is received or the waiting time has expired, the «485» indicator goes out.

In the remote server redirection mode, if a connection is established with a remote MODBUS TCP server, requests to other devices are also sent to this server, and a response is expected from it.

Note

The response is received from the first responding addressee, so there should not be devices with the same MODBUS addresses in the MODBUS network and among the addressees accessible via the remote MODBUS TCP server.

If the request could not be redirected (for example, in the slave mode, if the connection to the remote MODBUS TCP server was terminated), EM-483 can generate and transmit to the client the user-specified MODBUS exception code (by default, code 10).

If there is no response, EM-483 can generate and transmit the user-specified MODBUS exception code (by default, code 11) to the client.

If a response to the request has been received, EM-483 transmits it to the client that sent the request.

EM-483 Operation in Tunnel Mode

In tunnel mode EM-483 receives data "as is", without protocol check, and sends them to all other directions, for which this mode is selected. This allows transmitting data in a format other than MODBUS protocol. For example, arbitrary data received via RS-485 can be forwarded to a remote server, and vice versa.

The tunnel can be selected separately for each connection to the remote server and for the RS-485 interface. In the latter case, since the data format for incoming connections to the optional TCP port is the same as for RS-485, the tunnel mode will be enabled for these connections as well.

A data packet from one direction is received in its entirety (for Ethernet TCP it is the content of one TCP packet, for RS-485 the packet length is determined by the MODBUS RTU maximum pause rules), then sent to the other tunnel directions in turn. The maximum length of a data packet is 254 bytes.

Setting Up

The configurable parameters are described in Appendix C - MODBUS Registers. The parameters are saved when the power is turned off.

There are two ways to configure the product:

- Via the WEB-interface;
- Via the MODBUS-interface.

Important

When changing the product parameters, values can be set that impede or block the connection to the product over the network. In this case, the parameters should be reset so that they comply with the factory values.

Restarting the product or resetting the settings to make them comply with the factory values is performed using the «R» button accessible through the hole on the front panel. The button must be pressed by a thin non-conductive object.

Reset to Manufacturer's Defaults

1. Press and hold the reset button «**R**» for at least 8 seconds (after 2 seconds of holding the button, the indicator «**Δ**» will light up), after 8 seconds, the product will get restarted, the indicators will flash and go out.
2. Release the «**R**» button.

Restart with Saved Settings

1. Press and hold the reset button «**R**» for 2 to 8 seconds.
2. After the «**Δ**» indicator lights up, release the «**R**» button.

Configuring EM-483 via the MODBUS Interface

Configuration via the MODBUS interface is performed when connecting to the product using a MODBUS client IP address (factory value – 192.168.0.111) specifying the MODBUS identifier EM-483 (factory value – 111).

To configure the parameters, write the password string into the password input parameter (see Current Mode Parameters). The factory password value is «11111», i.e. to write the factory password into registers 0 to 4, write the number 49 – the ASCII code of the unit. If the password is specified correctly, the mode register (see Current State Parameters) will take the value «1» – the setting mode.

In the setup mode, the control command parameter is available for recording, as well as the setup parameters (listed in Settings). After writing the desired values into the configuration parameters registers, write the value «2» – the «Save» command to the control command parameter. The correctness of the saved parameters values can be checked by comparing the sets of configurable parameters and the saved parameters. If the sets match, the new settings have been accepted and saved.

To apply parameters without restarting the product, write the value «4» into the control command parameter – the «Save and Apply» command. Only MODBUS and custom parameters can be applied without restarting the product. The correctness of the saved parameters values can be checked by comparing the sets of configurable parameters and the current parameters. If the sets match, the new settings have been accepted and saved.

To cancel changes in the parameters before saving them, write the value «9» in the control command parameter – the «Cancel» command. In this case, the configurable parameters take the values of the saved ones.

To reset the saved parameters to the factory values in the setup mode, write the value «444» in the control command parameter – the «Return to Factory» command.

In order for the stored parameter values to take effect, the product must be restarted. Via the MODBUS interface, the restart is performed by writing the value «1» to the control command parameter – the «Restart» command.

To exit the setup mode, write 0 to the first register of the password input parameter. In this case, all the password input registers and the control command register are cleared (they take the value «0»).

Configuring EM-483 via the WEB Interface

The configuration via the WEB-interface is performed using a WEB-browser. Write the IP address of the product in the address bar of the browser (the factory value is 192.168.0.111) and select the transition to the specified address.

Note

If the browser is configured to use a proxy server, then to access the product on the local network, you must add its IP address to the exceptions in accordance with the documentation for the browser.

The main page will be displayed with the tab titles for switching over to other modes.

To configure the product parameters, select the «Settings» tab.

You will be prompted for a password to access the settings (the factory value is «1111»).

After entering the password and pressing the «Login» button, if the password is specified correctly, access to the configuration mode must be allowed. The settings page appears. If the password is incorrect, you will be prompted for the password again.

The settings on the settings page are grouped by purpose and divided into bookmarks. Non-configurable parameters and measurements are available on the «Status» tab. The settings on the other tabs are listed in the Settings.

After making changes to the parameters, click the «Save» button. In this case, the entered parameters will be checked. If there are no errors in the parameter values, the parameters will be stored in the EM-483 memory (the new parameters will take effect after the next parameter application or restart). If errors are found in the parameters when clicking the «Save» button, none of the parameters are saved, and the names of the erroneous parameters are highlighted in red.

To apply the parameters without restarting the product, click the «Apply» button at the bottom of the page. In this case, the entered parameters will be checked. If there are no errors in the parameter values, the parameters will be stored in the EM-483 memory and will take effect. Only MODBUS and custom parameters can be applied without restarting.

When you click on the «Return to Factory» button, all parameters take their factory values.

When the «Restart» button is clicked, all connections and incoming/outgoing operations are interrupted, and the EM-483 is restarted. If changes in the parameters have been made and stored in the product's memory before, these changes will take effect.

Note

If the address settings on the Ethernet network (MAC addresses, IP addresses, DHCP settings) have been changed and saved, the browser may not load the page in response to clicking the «Restart» button. This is caused by the browser accessing the previous address. In this case, the connection should be made again.

When you click on the «Exit» button, the setup mode is closed, and the password request is displayed again.

Firmware Update

EM-483 stores two update files in its memory:

- The file «**EM483FW1.FUS**» can be downloaded via the WEB-interface;
- The file «**EM483FW0.FUS**» is downloaded by the manufacturer and cannot be replaced; in case of a failure during the update process (for example, power supply loss), the file is used for automatic recovery.

Any of these files can be obtained from the EM-483 memory (for loading into another EM-483 product). The installed firmware can be updated from these files remotely via MODBUS or WEB-interface.

Transfer of EM-483 Update Files

Remote download via MODBUS:

1. Connect to configure the product via MODBUS (see section Configuring EM-483 via the MODBUS Interface).
2. To check the version of the downloaded update file, read the header line in registers 2030-2061.
3. To start downloading the new version from the cloud server into the downloaded update file, write the value «64893» into the control command parameter.
4. Control the downloading of the file by reading registers 2004-2005.
5. After downloading, check the version of the downloaded file again.

Upload via WEB-interface:

1. Enter the EM-483 configuration mode via WEB-interface.
2. Go to the «Files» tab.
3. Select the file «EM483FW0.FUS» or «EM483FW1.FUS».

To upload a file to EM-483:

1. Click the file selection button.
2. In the window that opens, select the update file (for example, «EM-483-5-2-6.FUS»).
3. Click the «Send» button.

Note

After downloading the file, make sure that you have downloaded the correct software update file to the correct version. The firmware title with the version number should be displayed next to the file name.

To get a file from EM-483:

1. Click the «Receive» button.
2. Select the file name and the location where the file will be placed.

To erase the contents of the EM-483 file, click the «Erase» button.

Firmware Update by External Command

Remote software update via MODBUS:

1. Connect to configure the product via MODBUS (see section Configuring EM-483 via the MODBUS Interface).
2. Read the header line in registers 2030-2061 to check the version of the downloaded update file.
3. If the required file is loaded, write the value «65397» to the control command parameter to start the update.

Update via WEB-interface:

1. Enter EM-483 configuration mode via WEB-interface.

2. Go to the «Files» tab. Select the file «EM483FW0.FUS» or «EM483FW1.FUS».
3. Press the «Program» button.

The product will automatically restart and enter the update mode. Wait for the software update, the process may take from 1 to 3 minutes. Then connect to the EM-483 (via WEB-interface or MODBUS-interface). Check the version number and make sure that the update was successful.

Complete Set

Item	Quantity
Protocol converter EM-483	1 pcs.
Ethernet connection cable	1 pcs.
Operating manual	1 pcs.
Packaging	1 pcs.

Maintenance

Recommended frequency of maintenance is every six months.

Maintenance Procedure:

1. Check the connection reliability of the wires, if necessary, clamp.
2. Visually check the integrity of the housing, in case of detection of cracks and damages take the product out of service and send for repair.
3. If necessary, wipe the front panel and the housing of the product with cloth.

Caution

Do not use abrasives and solvents for cleaning.

Safety Precautions

STRICTLY PROHIBITED

- To carry out installation works and maintenance without disconnecting the product from the mains;
- To open and repair the product without any professional help;
- To operate the product with mechanical damages of the housing.

It is not allowed water penetration on terminals and internal elements of the product.

During operation and maintenance, the regulatory document requirements must be met, namely:

- Regulations for Operation of Consumer Electrical Installations
- Safety Rules for Operation of Consumer Electrical Installations

- Occupational Safety in Operation of Electrical Installations

Transportation and Storage

The product in the original package is permitted to be transported and stored at the temperature from minus 45 to +60 °C and relative humidity of no more than 80 %.

Service Life and Manufacturer Warranty

- **Lifetime:** 10 years. Upon expiration of the service life, contact the manufacturer.
- **Shelf life:** 3 years.
- **Warranty period:** 5 years from the date of sale.

During the warranty period of operation (in the case of failure of the product) the manufacturer is responsible for free repair of the device.

ATTENTION

IF THE PRODUCT HAS BEEN OPERATED IN VIOLATION OF THE REQUIREMENTS OF THIS MANUAL, THE USER WILL LOSE THE RIGHT TO WARRANTY SERVICE.

Warranty service is performed at the place of purchase or by the manufacturer of the product.

Post-warranty service of the product is performed by the manufacturer at current rates.

Before sending for repair, the product should be packed in the original or other packing which prevents mechanical damage.

Manufacturer Contact

"Novatek-Electro" Ltd.

- Website: www.novatek-electro.com
- Address: 59, Mykhailo Boltenko (Admiral Lazarev) str., Odesa, Ukraine, 65007
- Tel: +38 (067) 565 37 68; +38 (050) 359 39 11; +38 (063) 301 30 40

Appendix A: Connecting to the Server

The EM-483 has a continuous communication mode with the data acquisition and management server. The server can be, for example, the Overvis system (Internet-address «overvis.com»).

ATTENTION

The service may be chargeable.

About Overvis

Overvis is a system for monitoring and remote control of technological processes. Overvis allows you to:

- Read data and manage devices including EM-483 when connected to them
- Save data and then convert and view them in a convenient form
- Receive alerts about accidents in the form of SMS or E-Mail

The factory settings of EM-483 are prepared for connection to Overvis.

Product Registration

The Overvis system supports a special identification method used in the product. In this case, the products are recognized by a unique MAC address, which is transmitted to the server each time you connect.

There are two ways to register the product for the user of the Overvis system:

Option A: QR Code Registration

If the product has a sticker with a QR-code, read the code and click on the link or enter the link from the sticker manually and then follow the instructions of the server.

Option B: Activation Code Registration

Specify the activation code in the Overvis user account. The code is a number of 8 characters displayed on the status page of the product WEB-interface after connecting to the server. When you enter the code, the EM-483 “links” to the user account.

Connecting a New Product to Overvis

To connect a new product to the Overvis system using an activation code, you must:

1. Connect the EM-483 to the Internet using one of the above methods.
2. Make sure (on the product WEB-interface status parameters page, in the «Data Collection Server» field), that the connection to the server is established and the activation code is received.

 **Caution**

If a product, which is being reconnected to Overvis, displays information that the connection has been activated or that the connection has no code, then for security reasons, click the «Restart Activation» button at the bottom of the status page, in the settings adjustment via the WEB interface, to remove the product from Overvis. This ensures that EM-483 will only be used by eligible users.

3. Using the instructions on the Overvis website, connect to EM-483 with the activation code.

4. After activation, the status page will display the message «Active».

The message «No Code» means that the product was registered using the QR-code on the sticker.

 **ATTENTION**

TO CONNECT EM-483 TO OTHER SERVERS, CONTACT THE MANUFACTURER!

Appendix B: Web Interfaces

To access the product using a browser, EM-483 waits for an Ethernet connection to port 80 and for HTTP protocol transfers. To make a connection, call the IP address of the product (the factory setting is 192.168.0.111) from the browser's address bar. The browser displays WEB pages that allow you to read the product status, configure parameters, call the MODBUS functions, and perform file operations.

In addition, the HTTP connection can be used by other applications to automatically call the MODBUS functions using API.

EM-483 supports API in two formats: JSON and XML. For example, if the IP-address of the product is "192.168.0.111", then the JSON API request without parameters will look like 192.168.0.111/api.json, and the XML API will look like 192.168.0.111/api.xml (in the examples below, each request starts with one of these lines, and this beginning is designated as <API call>).

API Response Without Parameters

An example of a response to a request is given below.

JSON format:

```
{
  "type": "EM-48x API",
  "version": "1.1",
  "device": "EM-483",
  "firmwareVersion": 6,
  "loginChallenge": "92uJz89fQEd62Jx0W75sGtNAm"
}
```

XML format:

```
<ApiReply>
  <Type>EM-48x API</Type>
  <Version>1.1</Version>
  <Device>EM-483</Device>
  <FirmwareVersion>6</FirmwareVersion>
  <LoginChallenge>92uJz89fQEd62Jx0W75sGtNAm</LoginChallenge>
</ApiReply>
```

Response Fields Description

JSON	XML	Description
(unnamed)	ApiReply	Root element of the response
type	Type	Response type (always "EM-48x API")

JSON	XML	Description
version	Version	Answer version
device	Device	Device
firmwareVersion	FirmwareVersion	Firmware version
loginChallenge	LoginChallenge	Secure authorization offer (see below)

Authorization

Access to MODBUS requires authorization, which can be performed in two ways:

1. **Unprotected password** – by sending an API request with the password string in the `plainpass` parameter.
2. **SHA-1 protection** – using the authorization offer received in the `loginChallenge` field. To do this, calculate the standard SHA-1 hash of the string made up of the authorization offer and password, and then send an API request with the hash string (encoded in hexadecimal form or according to the BASE-64 standard) in the `lcanswer` parameter.

For example, for the EM-483 factory password "11111" and the sentence in the example above, the hash of the composite string "92uJzC89fQEdB62JxOW75sGtNAmA11111" in hexadecimal form is 28457e7fc55a67bf59caf5f73e42fd168a5fe6a3.

Upon successful authorization, the product returns the response redirecting it to the session page, for example, `/1c193447/api.xml` (further in the examples `<API session call>`), where "1c193447" is the temporary session code. If the application sending the request does not support redirection, then the requests should be called with the `redirects` parameter set to "0".

Authorization Response Example

The response to the request `<API call?lcanswer=28457e7fc55a67bf59caf5f73e42fd168a5fe6a3&redirects=0`, if it was sent after the response in the example above:

JSON format:

```
{
  "session": "1c193447",
  "status": "Ready"
}
```

XML format:

```
<ApiReply>
  <Session>1c193447</Session>
  <Status>Ready</Status>
</ApiReply>
```

Authorization Response Fields

JSON	XML	Description
session	Session	Session code. The absence of this element means that authorization is required. Authorized requests start with <API session call> with the specified code.
status	Status	Status of MODBUS calls: "Busy" – MODBUS call is being processed, repeat the call without parameters to get the result or to send a new call; "Ready" – a new MODBUS call can be sent.

MODBUS Call Parameters

The parameters listed below are used to call MODBUS.

Parameter	Range of Values	Description
mbc_uid	0–255	Identifier of the destination device
mbc_func	1–6, 15–16	MODBUS function code. For write functions, only one value can be written including the same for multiple write functions (codes 15 and 16).
mbc_addr	0–65535	Register, flag, or digital input address
mbc_data	0–65535	For read functions – the number of values to be read (from 1 to 16). For write functions – the value to be written.
dosend	0–65535	The presence of this parameter in the request with any value makes a MODBUS call with the specified parameters

MODBUS Call Response Example

The response to <API session call>?mbc_uid=111&mbc_func=3&mbc_addr=168&mbc_data=2&dosend=1 (for the EM-483 own identifier value, which is equal to the factory one "111") – reading the Operating Time:

JSON format:

```
{
  "type": "EM-48x API",
  "status": "Ready",
  "modbusQueries": [
    {
      "unitID": 111,
      "function": 3,
      "address": 168,
      "data": 2,
      "response": {
        "data": [0, 408]
      }
    }
  ]
}
```

XML format:

```
<ApiReply>
  <Type>EM-48x API</Type>
  <Status>Ready</Status>
  <ModbusQuery>
    <UnitID>111</UnitID>
    <Function>3</Function>
    <Address>168</Address>
    <Data>2</Data>
    <Response>
      <Data>0</Data>
      <Data>408</Data>
    </Response>
  </ModbusQuery>
</ApiReply>
```

Successful MODBUS Call Response Fields

JSON	XML	Description
modbusQueries	ModbusQuery	MODBUS request
unitID	UnitID	Identifier of the destination device in the request
function	Function	MODBUS function code in the request
address	Address	Address of the register, flag, or quantized input in the request

JSON	XML	Description
response	Response	Response to the request
data	Data	In the request – the number of values to read or write, in the response – the data read or written

MODBUS Call Error Response Fields

JSON	XML	Description
errorInQuery	ErrorInQuery	MODBUS request error (the field is in the request instead of the response field): "Query unit ID illegal" – incorrect device ID; "Query address illegal" – invalid address; "Query data illegal" – invalid value
errorInResponse	ErrorInResponse	MODBUS response error (the field is in the request instead of the response field): "Response mismatch" – the received response does not match the request
exceptionCode	ExceptionCode	MODBUS exception code (the field is in the response instead of the data field)
exception	Exception	The MODBUS exception text corresponding to the code (the field is in the response instead of the data field)

Appendix C: Modbus Registers

Parameter Sets Available via MODBUS Protocol

The parameter sets available via the MODBUS protocol are listed below. The internal structure of all parameter sets is similar to that of the set described in Settings, except for the start address.

Setting	Description	Access	Addresses
Alterable settings	The parameters listed in Settings, that can be changed and enabled as described in Configuring EM-483 via the WEB-interface and MODBUS-interface	Only in setup, read or write mode	300 – 799, 5250 – 5499
Current settings	The parameters used at the moment	In any mode, read-only	2300 – 2799, 5500 – 5749
Saved settings	The set is saved regardless of whether the power is available and is used at startup	Only in setting mode, read-only	3300 – 3799, 5750 – 5999

Format of Parameters Presentation in MODBUS Registers

Parameter	Range of Values	Description	Number of Occupied Registers
Number	0 – 65535	Integer number (16 bits) in the standard range of the MODBUS register values	1
Number	0 – 4294967295 in two registers, the upper part is the first one	Integer number whose value may be greater than the MODBUS register limit (65535)	2
String of characters	In each register, ASCII is the character code or 0 (the end of the string)	A set of values, each of which is equal to code 1 of the character in ASCII coding. If a string is shorter than the greatest length, code 0 is placed after the last character	The longest string for the given parameter
IP address (IP mask)	One byte (0 – 255) in each register	A set comprised of four bytes of IPv4 address, left to right	4
MAC address	One byte (0 – 255) in each register	A set comprised of six bytes of MAC-48 address, left to right	6

Device Describing Parameters

Parameter	Description	Address
Type of the product	The code determining the MODBUS product at the manufacturer's (33 – EM-483)	0
Software version	Version of the embedded software	1
Check code	CRC32 of the embedded software	2–3

Current Mode Parameters

Parameter	Values Range	Initial Value	Description	Address
Password entry	String of characters	0	When entering a valid password, the client is granted the appropriate permission (registers 510 – 549). When entering an empty string, the client's rights are reset to the level of rights at the time of connection	100–119
Control command	0–444, 64893, 65397, 65407 (writing in the setup mode)	0	0: no action; 1: «Restart» – means EM-483 restart; 2: «Save» – means saving the altered settings; 3: «Apply» – means to apply settings without restart (accessible only for MODBUS parameters and user's ones); 4: «Save and apply» – means the same as orders 2 and 3 sent one after another; 6: «Export» – means read the saved settings and write them into the file; 7: «Import» – means read the settings from the file and save them in the internal memory; 9: «Cancel» – means read the saved settings; 51: «Apply for MODBUS» – means apply the settings to the MODBUS network and MODBUS TCP; 59: «Apply to user's» – means apply the settings to the user's register area; 444: «Restore factory settings» – means reset the settings to their factory values; 64893: «Download updates» – start downloading the latest firmware version from the cloud server to the downloaded firmware file; 65397: «Update firmware» – program from the downloaded file; 65407: «Return firmware» – program from the factory file	120

Current State Parameters

Parameter	Description	Address
Mode (for more details, see reg. 122)	0: User's mode; 1: Setting mode	121
Access mode flags	See Access Mode Flags table below	122
Time, minutes	Number of minutes after start-up	123–124
Clients number	Number of busy connections	125

Parameter	Description	Address
Clients limit	Total number of possible clients	126
Load RS-485, requests/sec	Number of requests sent via RS-485 per second	127
RS-485 useful load, requests/sec	Number of answers without errors via RS-485 per second	128
RS-485 load per second, %	RS-485 business within the last second in consideration of the RS-485 rated speed and silence time	129
RS-485 load during a minute, %	RS-485 business within the last minute	130
RS-485 load during 5 minutes, %	RS-485 business with the last five minutes	131
MODBUS TCP load, requests/sec	Number of requests received from the clients via MODBUS TCP per second	132
MODBUS TCP useful load, requests/sec	Number of answers without errors sent to clients via MODBUS TCP per second	133
Ethernet load, ×100 kB/s	Wire channel load with the Ethernet switched on	135
Maximum clients	The maximum number of simultaneously connected clients from the moment of start-up	136
Maximum MODBUS TCP load, requests/sec	The maximum number of requests received from clients via MODBUS TCP within one second from the start-up moment	137
Maximum RS-485 load, %	The maximum RS-485 load during 5 minutes after start-up	138
Ethernet current IP-address	IP-address, at which EM-483 is accessible on the Ethernet network	140 – 143
Ethernet current MAC-address	MAC-address, at which EM-483 is identified on the Ethernet network	144 – 149
Time before connection to the data collection server, sec	0: connection with the data collection server is established; 1: connecting to the data collection server; 2 – 65534: the number of seconds prior to reconnection; 65535: connection to the server is not used	165
Number of programmed restarts	The number of restarts according to the user's set-up during the whole time of operation	166
Number of critical errors	The number of noted errors (malfunctions) that caused the product restart during the whole time of operation	167

Parameter	Description	Address
Total time of work, min	Number of the product operating minutes during the whole time of operation	168 – 169
Time, sec	Number of seconds from start-up	170 – 171
Power voltage, mV	Voltage on the product power supply terminals	175
Time prior to connection to the 1st remote server, sec	0: connection with the remote server is established; 1: connecting to a remote server; 2–65534: number of seconds prior to reconnection; 65535: connection to the remote server is not used	176
State of connection to the 1st remote server	0: no connection; 1: Ethernet connection is established	177
Time prior to connection to the 2nd remote server, sec	Similarly, reg. 176	240
State of connection to the 2nd remote server	Similarly, reg. 177	241
Firmware update download status	See Firmware Download Status Flags table below	2004
Firmware file download progress, × 0.01%	Downloaded part of the full file size. 10000 – file is completely downloaded	2005
Title of the downloaded firmware file	Version identifier string, e.g. "EM-483 ver.6". Empty string – file not checked or incorrect	2030 – 2061
User's parameters of state	Reset to 0 at restart. Can be used for temporary storage and transfer to the server of data received from connected clients	5000 – 5249

Access Mode Flags (Register 122)

Bit	Description
Bit 0	The ability for the connected client to obtain permission (using a password) for requests to get reading functions of devices via MODBUS: 0: permission cannot be obtained; 1: permission is issued upon the password is provided
Bit 1	Permission for the connected client to request device read functions via MODBUS: 0: no permission; 1: permission is given
Bit 2	The ability for the connected client to obtain permission (using a password) for requests for write and device management functions via MODBUS: 0: permission cannot be obtained; 1: permission is issued upon the password is provided

Bit	Description
Bit 3	Permission for the connected client to request for write and device management functions via MODBUS: 0: no permission; 1: there is a permission
Bit 4	The ability for the connected client to obtain permission (using a password) to access the EM-483 registers, except for the registers of version, password, mode, and access flags: 0: permission cannot be obtained; 1: permission is issued after the password is provided
Bit 5	The ability for the connected client to obtain permission (using a password) to access the EM-483 registers, except for the registers of version, password, mode, and access flags: 0: no permission; 1: permission is issued
Bit 6	Always 1
Bit 7	Permission for the connected client to configure EM-483 (similar to register 121): 0: no permission; 1: there is a permission

Firmware Download Status Flags (Register 2004)

Bit	Description
Bit 1	Busy indication: 0 – waiting for command; 1 – receiving file
Bit 2	Receiving updates error: 0 – no stop with error; 1 – error
Bit 3	Connection to the server: 0 – no connection with the server; 1 – connection established
Bit 4	Retrieving file data: 0 – no file data; 1 – data downloaded
Bit 6	File download completion: 0 – file has not been downloaded; 1 – file has been completely downloaded
Bit 7	File correctness: 0 – no confirmation; 1 – file is correct

Settings

Ethernet Network

Parameter	Range	Factory Value	Description	Address
Static IP address	IP-address	192.168.0.111	If the dynamic addressing is disabled or inaccessible, the IP address on the Ethernet network is equal to this value	300 – 303
Subnet mask	IP mask	255.255.255.0	This is used only together with the static IP address	304 – 307
Gateway	IP-address	192.168.0.1	This is used only together with the static IP address for the connection with other networks or as the address of DNS/DHCP servers	308 – 311

Parameter	Range	Factory Value	Description	Address
DHCP dynamic addressing mode	0 – 2	1	0: the specified values of the gateway, mask, and static IP address are used for addressing in Ethernet; 1: The product uses the network's DHCP server to determine the gateway, mask, and masked part of the IP address that denotes the network. The remaining part of the address is used from the specified static address. If the server is unavailable, static addressing values are used; 2: The product uses the DHCP server to determine the gateway, mask, and IP address	312
Switch on the IP address filter of the DHCP server	0 – 1	0	This is used for dynamic addressing. 0: receiving the addressing data from the DHCP server that answered first; 1: receiving the data of addressing only from the DHCP server with the IP address of the gateway	313
Switch on the use of the gateway DNS server	0 – 1	1	This is used, if DHCP is inaccessible (switched off). 0: Gateway DNS is not used; 1: Gateway DNS is used to identify IP addresses of other servers, if they are set by host names	314
IP address of DNS server	IP-address	8.8.8.8	This is used, if DHCP is inaccessible (switched off). When it is switched on and the gateway DNS server is used, the IP-address of the DNS additional server is set	315 – 318
IP address of the DNS additional server	IP-address	0.0.0.0	This is used, if DHCP is inaccessible (disabled). 0.0.0.0: is not used	319 – 322
Switch on the MAC address redefinition	0 – 1	0	0: the value unique for each product is used as the MAC address; 1: the manually set MAC address is used	323
Ethernet MAC address set manually	MAC address	Unique for each product	This is used when MAC manual address is on for identification of the product on the Ethernet network	324 – 329

MODBUS Network

Parameter	Range	Factory Value	Description	Address
Optional MODBUS RTU/ASCII	0 – 65535	0	Used for external connection to EM-483 via Ethernet for exchange via MODBUS RTU, MODBUS ASCII protocol or in tunnel mode. The format is the same as used for RS-	335

Parameter	Range	Factory Value	Description	Address
connection port via TCP or in tunnel mode			485 interface (reg. 463, 637). For MODBUS – only packets containing whole frames are processed, if TCP packets are fragmented, the connection is closed. 0 : connection is not used	
Connection port via MODBUS TCP	1 – 65535	502	This is used for external connection to EM-483 via Ethernet for exchanging with the use of MODBUS TCP protocol	450
Disconnect inactive clients	0 – 1	1	0 : incoming connection is supported regardless of the time between requests from the client; 1 : disconnect the clients, from whom no requests have been received longer than the set time	451
The longest request wait time, sec	0 – 600000	90	This is used, if the disconnection of inactive clients is selected	452 – 453
Enable queue for the last busy MODBUS TCP connection	0 – 1	0	0 : MODBUS TCP connection is supported regardless of the connection hold time; 1 : If all MODBUS TCP connections are busy, the new client requesting a connection can be connected instead of the last connected client if the connection hold time is longer than the specified one	454
Maximum hold time for the last MODBUS TCP connection, msec	0 – 600000	60000	This is used, if the queue for the last MODBUS TCP connection is enabled	455 – 456
Native MODBUS Identifier EM-483	0 – 247	111	0 : All MODBUS TCP requests are forwarded to the MODBUS network, the product registers are not available via MODBUS TCP; 1-247 : The product responds to MODBUS TCP requests with this MODBUS ID without forwarding them to the MODBUS network	457
RS-485 data transfer rate, bit/s	75 – 281250	9600	This is used when exchanging with devices via RS-485, the same value for devices on the same bus	458 – 459
Enable byte format selection in RS-485 transmissions	0 – 1	1	This is used when exchanging with devices via RS-485, the same value for devices on the same bus. 0 : This is not used, the byte ends with 2 stop bits; 1 : The byte format is selected from register 461	460
Byte format in RS-485	0 – 5	5	This is used when communicating with devices via RS-485 only if byte format selection is enabled. The same	461

Parameter	Range	Factory Value	Description	Address
transmissions			value for devices on the same bus. 0: "EVEN" – 1 parity bit and 1 stop bit; 1: "ODD" – 1 parity bit and 1 stop bit; 2: "0" ("SPACE") – 1 zero bit and 1 stop bit; 3: "1" ("MARK") – 1 single bit and 1 stop bit (similar to the mode with two stop bits); 4: "MISSING" – no parity bit, 1 stop bit; 5: "AUTO-STOP" – no parity bit, 2 stop bits in the sent bytes, 1 stop bit in the received ones (devices with 1 and 2 stop bits can be connected at the same time)	
Wait time for the start of the MODBUS RTU response, msec	0 – 60000	200	Used for RS-485 transmissions in MODBUS RTU mode or tunnel mode. After sending the request, if the first byte of the response was not received within this time interval, the waiting for the response is terminated. The response is always expected to be at least the time of silence between frames (the time of silence depends on the transfer rate and is equal to the transfer time of 3.5 bytes or 1.75 ms for speeds over 19,200 bps)	462
Enable ASCII exchange mode in the MODBUS network	0 – 6	2	MODBUS exchange mode, the same value for devices on the same bus. 0: RTU exchange mode (format: 1 start bit, 8 data bits, 2 stop bits, parity bit and stop bit, or only 1 stop bit – only 10 to 11 bits); 1: ASCII exchange mode (format: 1 start bit, 7 data bits, 2 stop bits or parity bit, and stop bit – 10 bits in total). Non-standard byte formats (register 461, values 4 and 5) are not available, but the format 3 (2 stop bits) is used instead; 2: similar to "0", but with increased silence time between frames by 2 times; 3: similar to "2", but 4 times; 4: similar to "2", but 8 times; 5: similar to "2", but 16 times; 6: similar to "2", but 32 times	463
Waiting time for the next MODBUS ASCII character, ms	0 – 60000	1000	Used for RS-485 transmissions in MODBUS ASCII mode. When receiving a response, if the next byte of the response was not received during this time interval, the waiting for the response is terminated. The waiting time is always equal at least to the transmission time of one character (depends on the transmission speed)	464

Connecting to the Data Collection Server

Parameter	Range	Factory Value	Description	Address
Data collection server connection mode	0 – 2	1	0: connection to the server is not used; 1: connection to the server is established and maintained through the specified server connection port (the port on the server side);	465

Parameter	Range	Factory Value	Description	Address
			2: passive mode, the server is expected to connect via the specified server connection port (the port is on the EM-483 side)	
Server connection port	0 – 65535	20502	The port that is accessed by the party establishing the connection between the EM-483 and the server (see register 465)	466
Waiting time for a response from the server, sec	0 – 3600	120	0: server silence time is unlimited; 1-3600: the maximum server silence time, after which the connection will be terminated and must be re-established	467
Waiting time before reconnecting to the server, sec	0 – 30000	15	This is used when connecting to the server (except for the "2" mode). After the connection to the server is lost, the reconnection will be made after the specified waiting time (after starting the product, the first connection is made in fixed time – 5 seconds)	468
Enable setting the server address with a text string	0 – 1	1	This is used when connecting to the server (except for mode "2"). 0: the connection is made to the server with a fixed IP address given in registers 470-473; 1: the connection is made to the server with the name specified in registers 474-509	469
Server IP address	IP address	0.0.0.0	This is used when connecting to the server (except for the mode "2"), if setting the server address with a text string is disabled. The IP address of the remote server, connection to which is supported	470 – 473
Server address	String of chars	modbus.overvis.com	This is used when connecting to the server (except for mode "2"), if setting the server address with a text string is enabled. The address of the remote server, connection to which is supported. The address can be a string up to 36 characters long. There can be no spaces in the string	474 – 509

Protection

Parameter	Range	Factory Value	Description	Address
The specified password for entering the setup mode	String of chars	11111	This is used to access the configuration mode. The password can be a string of 5 to 10 characters long. There should be no spaces in the string	510 – 519
Set password for allowing MODBUS writing to devices via RS-485	String of chars		This is used to access devices connected to EM-483 to request the write or control functions that can change the state of these devices. The password can be a string up to 10 characters long. There should be no spaces in the string	550 – 559
The set password for allowing MODBUS reading	String of chars		This is used to access devices connected to EM-483 to request read functions or to access EM-483 registers other than version, password, mode, and flag registers. The password can be a string up to 10 characters long	560 – 569
Enable MODBUS write protection mode	0 – 1	0	0: write protection is controlled by other parameters (password) or disabled; 1: any function requests other than MODBUS functions 1, 2, 3, 4, 7, 17, 20 are blocked	572
Enable MODBUS read protection mode	0 – 1	0	0: read protection is adjusted using other parameters (password) or disabled; 1: requests for MODBUS functions 1, 2, 3, 4, 7, 17, and 20 are blocked, except for read by function 3 of registers of the version, mode and flags	573

Miscellaneous

Parameter	Range	Factory Value	Description	Address
Enable the product automatic restart	0 – 1	1	0: periodical restart is disabled; 1: the product gets restarted in a set period of time	630
Restart period, min	5 – 7200	120	This is used, if the automatic restart is enabled	631
Enable restart mode automatically only when there are no connections	0 – 1	1	This is used, if the automatic restart is enabled. 0: the product is restarted after a set period of time from the start-up; 1: the product is restarted after a set time interval from the last MODBUS transmission	632
MODBUS exception code generated when	0 – 255	1	0: if access to MODBUS registers is denied, no response is returned to the client; 1 – 255: if access	633

Parameter	Range	Factory Value	Description	Address
access is denied			is denied to the client that sent the request, this exception code is returned	
MODBUS exception code generated when there is no answer	0 – 255	11	0: if there is no response from the request recipient (Gateway Timeout), the response is not returned to the client; 1 – 255: if there is no response from the request recipient, this exception code is returned to the client	634
MODBUS exception code generated when there is no connection to the request destination	0 – 255	10	0: if there is no response from the request recipient (Gateway Path Unavailable), the response is not returned to the client; 1 – 255: if there is no response from the request recipient, this exception code is returned to the client	636
RS-485 transmission mode	0 – 2	0	0: master mode (Master). RS-485 is used to send requests; 1: slave mode (Slave). RS-485 is used to receive requests from an additional client; 2: tunnel mode, used for data transmission "as is", without protocol verification	637
The first MODBUS-identifier of the RS-485	1 – 255	1	The parameters define the range of MODBUS identifiers used on RS-485. In master mode, requests with addresses in this range (as well as broadcasts with address 0) are routed via RS-485. In slave mode, requests with addresses in this range (as well as broadcast and EM-483 requests) are received over RS-485	638
The last MODBUS identifier of the RS-485	1 – 255	255	See register 638	639

Connecting to the First Remote Server

Parameter	Range	Factory Value	Description	Address
Connecting to the First Remote Server	IP address	192.168.0.112	This is used when redirecting requests to a remote server is enabled. This is the IP address of the remote server, to which the connection is supported	640 – 643
Remote server connection port	0 – 65535	502	Used when redirecting requests to a remote server. The port of the remote server to which the connection will be established	644

Parameter	Range	Factory Value	Description	Address
Wait time for a response from the remote server, msec	0 – 60000	1000	This is used when redirecting requests to a remote server. After sending the request, if the correct response was not received during this time, the waiting for the response is terminated	645
Wait time before the reconnection to the remote server, msec	0 – 240	20	This is used when redirecting requests to a remote server. After the connection with the server is lost, the reconnection will occur in the set wait time	646
Remote server connection mode	0 – 3	0	0: remote server is not used; 1: connect to the server in MODBUS TCP mode; 2: similarly to 1 with virtual identifiers*; 3: connect to the server in tunnel mode	647
The first MODBUS-identifier of the remote server	1 – 255	1	This is used when redirecting requests to the remote server. The range of the MODBUS identifiers is used on the remote server. Requests with addresses in this range (and broadcasts with address 0) are sent to the MODBUS TCP remote server	648
The last MODBUS identifier of the remote server	1 – 255	255	See register 648	649

* In virtual identifiers mode, before redirecting a request to a remote server MODBUS TCP, the virtual identifier of the destination from the request is replaced with the real one so that the numbering in the server range starts with 1. For example, for the range 15-17, the virtual ID 16 will be replaced with the real one 2. The broadcast ID 0 is processed without changes.

Connecting to the Second Remote Server

Similar to registers 640–649, with the factory value of the remote server IP address being 192.168.0.113.

Parameter	Address
Remote server IP address	760 – 763
Remote server connection port	764
Wait time for response, msec	765
Wait time before reconnection	766
Remote server connection mode	767

Parameter	Address
First MODBUS-identifier	768
Last MODBUS identifier	769

Connecting to the Third Remote Server

Similar to registers 640–649, with the factory value of the remote server IP address being 192.168.0.114.

Parameter	Address
Remote server IP address	770 – 773
Remote server connection port	774
Wait time for response, msec	775
Wait time before reconnection	776
Remote server connection mode	777
First MODBUS-identifier	778
Last MODBUS identifier	779

Connecting to the Fourth Remote Server

Similar to registers 640–649, with the factory value of the remote server IP address being 192.168.0.115.

Parameter	Address
Remote server IP address	780 – 783
Remote server connection port	784
Wait time for response, msec	785
Wait time before reconnection	786
Remote server connection mode	787
First MODBUS-identifier	788
Last MODBUS identifier	789

Connecting to the Fifth Remote Server

Similar to registers 640–649, with the factory value of the remote server IP address being 192.168.0.116.

Parameter	Address
Remote server IP address	790 – 793
Remote server connection port	794
Wait time for response, msec	795
Wait time before reconnection	796
Remote server connection mode	797
First MODBUS-identifier	798
Last MODBUS identifier	799

User's Settings

Parameter	Range	Factory Value	Description	Address
User's settings and stored values	0 – 65535	0	May be used for storing any identification or other data	5250 – 5499

Virtual Registers

Parameter	Description	Address
Virtual registers	When accessing these registers, EM-483 transfers the request to another device. The real MODBUS identifier from the range 1-32 and the register addresses (in the range 0-999) depends on the virtual register address: $\langle \text{virtual register address} \rangle = 5000 + 1000 \times \langle \text{MODBUS identifier} \rangle + \langle \text{real register address} \rangle$	6000 – 37999